

DASA

LIGHT YOUR LIFE



DASA

LIGHT YOUR LIFE

INDICE

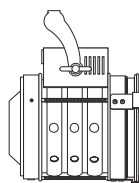

OSCAR P10-19

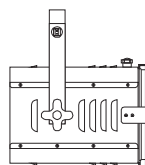

TABULA P20-27

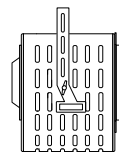

MITICO P28-35

PROIETTORI/PROJECTORS



VITTORIA P46-53

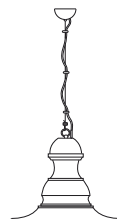

LISA P54-69



CLARA P60-65

SOSPENSIONI/SUSPENSIONS



GINA P92-95

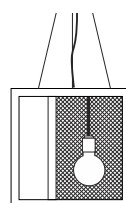

EVA P96-99



PEPE P100-103

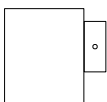

CUBETTO P124-133

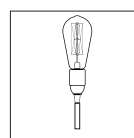

QUADRA P134-139

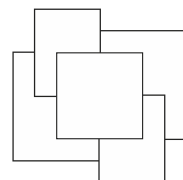

KATÀ P140-145

**LAMPADE A PARETE
WALL LAMPS**

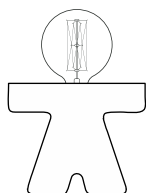

LOMINO P148-153

**LAMPADE DA TAVOLO
TABLE LAMPS**



MK P156-159



TR P160-163



BINARIO P166-169

TRAVI/TRUCK

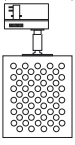

CUBETTO P36-43

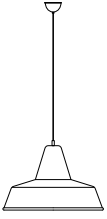

URBANA P66-71



BETTA P72-77

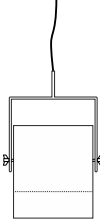

GAIA P78-85



OLIVIA P86-91



ZOE P104-107

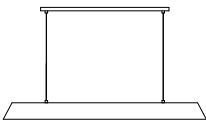

OPERA P108-115



FLAP LIGHT P116-121

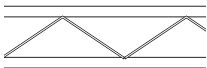

TRALICCIO P170-175



Officine Dasa fa parte di un corporate industriale, tutto italiano.

Specializzati nella progettazione e produzione di sistemi per l'illuminazione, ci avvaliamo delle più moderne tecnologie di produzione, realizzando tanto prodotti di serie, quanto custom made. La semplicità delle forme e l'originalità dei materiali scelti, rendono le nostre lampade di forte impatto decorativo, senza però rinunciare all'utilizzo e all'implementazione delle nuove tecnologie che permettono ai nostri prodotti di rispondere alle più moderne esigenze di risparmio energetico.

Caratterizzata da efficienza, dinamicità e flessibilità, Officine Dasa si propone di essere sempre vicino alle esigenze progettuali di Architetti e Lighting Designer, istaurando con loro un rapporto simbiotico che rende unico, pregevole e concreto lo sviluppo del contest pensato dall'arredatore. Il sogno e la filosofia di Officine Dasa nascono ripercorrendo le strade del passato in un virtuale viaggio nel tempo. L'archeologia industriale delle vecchie fabbriche italiane e degli studi cinematografici, che rappresentano uno dei più espressivi momenti storici della nostra "rivoluzione industriale", sono stati fonte di ispirazione per i nostri designer. Questa visione ha dato vita al nostro stile, un "sapore fortemente italiano e industriale", qualcosa che dia il giusto valore all'espressività del Made in Italy, in un contesto di globalizzazione culturale, sempre più incalzante.

La mission di Officine Dasa è dare forma a nuove idee e illuminare emozioni inesplorate.

Officine Dasa is part of an Italian industrial corporate.

Specialized in design and production lighting systems, we provide the most modern technology, manufacturing mass-produced articles and custom-made ones as well.

Form simplicity and originality of used materials, do make our lamps with a strong decorative impressive, but without renouncing to the use and implementation of new technologies, that let our products meet the modern safety and energy needs.

Being characterized as efficient, dynamic and flexible company, Officine Dasa is always following closely project requirements of architects and lighting designers, establishing a symbiotic relationship with them, that makes unique, valuable and concrete the development of the contest.

The industrial archeology of the old Italian studios and factories, one of the most expressive moments of our "industrial revolution", have been a source of inspiration for our designers. This vision inspired our style, a "strong Italian and industrial flavor", right expression of the Made in Italy.

The mission of Officine Dasa is give shape to new ideas and light up unexplored emotions.

PROIETTORI
PROJECTORS

PROIETTORI

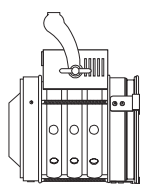

OSCAR

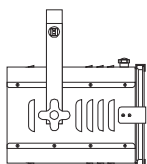

TABULA

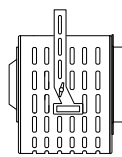

MITICO

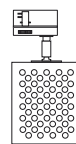

CUBETTO





Oscar, proiettore in alluminio tornito, è il risultato di una sapiente progettazione che riesce a fondere in un solo oggetto, forma, design e funzionalità. La caratteristica forma cilindrica lo rende perfetto per ogni esigenza di installazione sia di tipo commerciale che residenziale.

Disponibile in tre misure e differenti sorgenti luminose.

Oscar, projector in turned aluminum, is the result of design that manages form and function. The characteristic cylindrical shape makes it perfect for all installation requirements, commercial or residential.

Available in three sizes and different light sources.

OSCAR



OSCAR 4000



OSCAR 3000



OSCAR 2000

DESCRIZIONE: Proiettore in alluminio orientabile, da binario e superficie. Sorgente LED con driver incorporato, non direttamente sostituibile.

DESCRIPTION: Adjustable aluminium projector for track and surface. Led source with driver on board not direct replaceable.

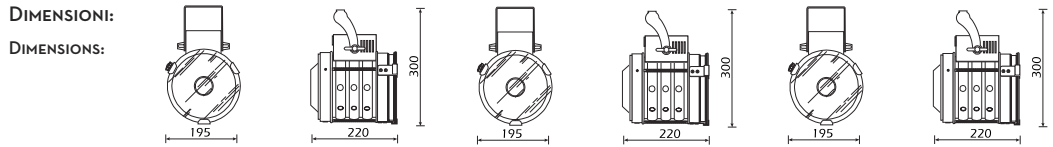

FINITURE: Alluminio naturale, nero opaco, bianco lucido.
FINISHES: Natural aluminum, matte black, glossy white.

ACCESSORI: DEF, GRF, CSK, KBM1, KPP/S, KPT, PZ-230, XTSAF, XTSAF-PG

Tutti i fari sono disponibili con due differenti angoli del fascio luminoso: 18° o 36°

CRI > 90 classe 1A

All the spots are available with two different beam angles: 18° or 36°

CRI > 90 1A class

Caratteristiche tecniche/Technical data

Code	4/18	4/36	3/18	3/36	2/18	2/36
Power	34,9W	34,9W	27W	27W	18,6W	18,6W
Flux	3800lm	3800lm	3000lm	3000lm	2310lm	2310lm
Kelvin	3000K	3000K	3000K	3000K	3000K	3000K
Beam	18°	36°	18°	36°	18°	36°
Efficacy	109lm/W	109lm/W	111lm/W	111lm/W	124lm/W	124lm/W
Int. protection	IP20	IP20	IP20	IP20	IP20	IP20
Energy efficiency	A+	A+	A+	A+	A+	A+

18°

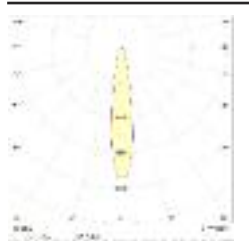

36°

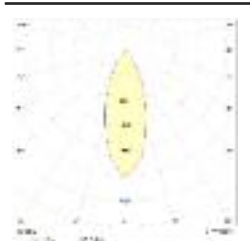

DEF 330X330MM
 Deflettore in alluminio naturale, bianco, nero
 Adjustable fins in aluminium, white, black



DEF 220X220MM
 Deflettore in alluminio naturale, bianco, nero
 Adjustable fins in aluminium, white, black



DEF 150X150MM
 Deflettore in alluminio naturale, bianco, nero
 Adjustable fins in aluminium, white, black



GRF 0270MM
 Griglia in filo di acciaio zincato
 Steel wire grid



OSCAR



OSCAR PAR 38



OSCAR PAR 30



OSCAR PAR 16

DESCRIZIONE: Proiettore in alluminio orientabile, da binario e superficie.
Sorgente LED 230V E27.
Non necessita di alimentatore.

Proiettore in alluminio orientabile, da binario e superficie.
Sorgente LED 230V E27.
Non necessita di alimentatore.

Proiettore in alluminio orientabile, da binario e superficie.
Sorgente LED 230V GU10.
Non necessita di alimentatore.

DESCRIPTION: Adjustable aluminium projector for track and surface. LED source 230V E27. No power supply needed.

Adjustable aluminium projector for track and surface. LED source 230V E27. No power supply needed.

Adjustable aluminium projector for track and surface. LED source 230V GU10. No power supply needed.

DIMENSIONI:

DIMENSIONS:

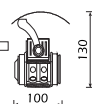
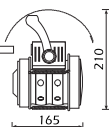
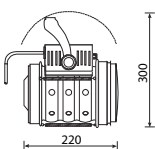
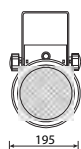

FINITURE: Alluminio naturale, nero opaco, bianco lucido.
FINISHES: Natural aluminum, matte black, glossy white.

Alluminio naturale, nero opaco, bianco lucido.
FINISHES: Natural aluminum, matte black, glossy white.

Alluminio naturale, nero opaco, bianco lucido.
FINISHES: Natural aluminum, matte black, glossy white.

ACCESSORI: DEF, KBM1, KPP/S, KPT, PZ-230, CSK, XTSAF, XTSAF-PG

DEF2, KBM2, PPK/S, TPK, CSK, PZ-230, XTSAF, XTSAF-PP

DEF3, CSK, KBM3, PPK/S, TPK, XTSAF, XTSAF-PP

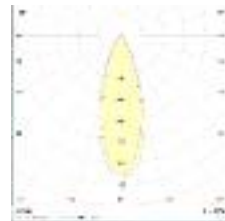
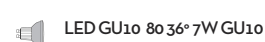
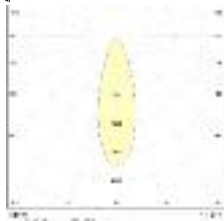
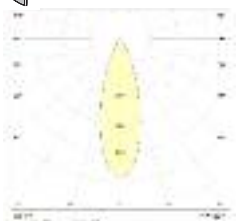

Caratteristiche tecniche lampadina/ Bulb technical data

	PAR38 led	PAR30 led	PAR16 led
Code	PAR38 led	PAR30 led	PAR16 led
Power	14W	9 W	6,7W
Flux	1035lm	766lm	575lm
Kelvin	2700K/3000K	2700K/3000K	3000K
Beam	30°	30°	36°
Dimensions	h135xØ121 mm	h96xØ92 mm	h58x Ø49,6 mm
Int. protection	IP20	IP20	IP20
Energy efficiency	A+	A+	A+



CSK L MAX 250CM
Cablaggio 3x0,75 con spina Schuko e connettore
Wiring 3x0,75 with Schuko plug and connector



KBM1 Ø120MM
Base di alluminio con cavo e connettore
Base supplied with wire and connector



KBM2 Ø88MM
Base di alluminio con cavo e connettore
Base supplied with wire and connector



KBM3 Ø58MM
Base di alluminio con cavo e connettore
Base supplied with wire and connector



PANTOGRAFO / PANTOGRAPH

Pantografo in acciaio zincato che permette di regolare ed estendere l'altezza dei corpi luminosi.

Può essere fissato alla trave oppure direttamente al muro ed è disponibile in due misure.

Pantograph in galvanized steel which allows you to adjust and extend the height of the bulbs. It can be fixed to the beam or directly to the wall and is available in two sizes.



KPP/S 250X200÷1000MM
Pantografo in acciaio zincato, cavo o spina Schuko
Galvanized steel pantograph, wire and Schuko plug



PPK/S 120X140÷400MM
Pantografo in acciaio zincato, cavo o spina Schuko
Galvanized steel pantograph, wire and Schuko plug



PZ-230 230X140MM
Pinza professionale per i fari presenti nel catalogo
Professional clamp for all the spot in the catalog



BG-65
Basamento da terra in fusione di ghisa
Iron cast basement for the floor.











Design essenziale per questo proiettore in alluminio. La gamma è stata recentemente ampliata integrando nuove sorgenti luminose, permettendo di esplorare nuove aree di applicazione. Disponibile in quattro misure, è idoneo sia per il montaggio a binario che per quello a soffitto o a parete.

Simple design for this projector in aluminum. The range has recently been expanded by other light sources, allowing you to explore new areas of application. Available in four sizes, for mounting on track, to the ceiling or wall.

TABULA



TABULA 4000



TABULA 3000



TABULA 2000

DESCRIZIONE: Proiettore in alluminio orientabile, da binario e superficie.
Sorgente LED con driver incorporato, non direttamente sostituibile.

DESCRIPTION: Adjustable aluminium projector for track and surface.
Led source with driver on board not direct replaceable.

DIMENSIONI:
DIMENSIONS:

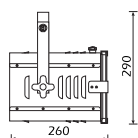
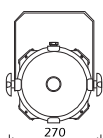
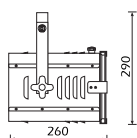
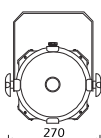
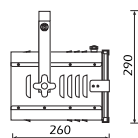
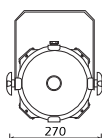

FINITURE: Alluminio naturale, nero opaco, bianco lucido.
FINISHES: Natural aluminum, matte black, glossy white.

FINITURE: Alluminio naturale, nero opaco, bianco lucido.
FINISHES: Natural aluminum, matte black, glossy white.

FINITURE: Alluminio naturale, nero opaco, bianco lucido.
FINISHES: Natural aluminum, matte black, glossy white.

ACCESSORI: DEF, GRF, CSK, KBM1, KPP/S, KPT, PZ-230, XTSAF, XTSAF-PG

ACCESSORI: DEF, GRF, CSK, KBM1, KPP/S, KPT, PZ-230, XTSAF, XTSAF-PG

ACCESSORI: DEF, GRF, CSK, KBM1, KPP/S, KPT, PZ-230, XTSAF, XTSAF-PG

Tutti i fari sono disponibili con due differenti angoli del fascio luminoso: 18° o 36°

CRI > 90 classe 1A

All the spots are available with two different beam angles: 18° or 36°

CRI > 90 1A class

Caratteristiche tecniche/Technical data

	4/18	4/36	3/18	3/36	2/18	2/36
Code	4/18	4/36	3/18	3/36	2/18	2/36
Power	34,9W	34,9W	27W	27W	18,6W	18,6W
Flux	3800lm	3800lm	3000lm	3000lm	2310lm	2310lm
Kelvin	3000K	3000K	3000K	3000K	3000K	3000K
Beam	18°	36°	18°	36°	18°	36°
Efficacy	109lm/W	109lm/W	111lm/W	111lm/W	124lm/W	124lm/W
Int. protection	IP20	IP20	IP20	IP20	IP20	IP20
Energy efficiency	A+	A+	A+	A+	A+	A+

18°

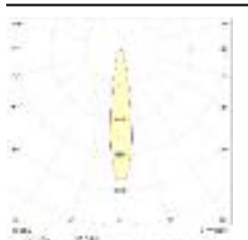

36°

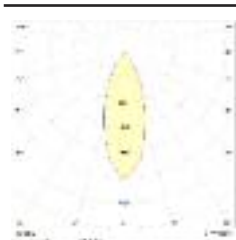

DEF 330X330MM
Deflettore in alluminio naturale, bianco, nero
Adjustable fins in aluminium, white, black



DEF1 260X260MM
Deflettore in alluminio naturale, bianco, nero
Adjustable fins in aluminium, white, black



DEF2 220X220MM
Deflettore in alluminio naturale, bianco, nero
Adjustable fins in aluminium, white, black



DEF3 150X150MM
Deflettore in alluminio naturale, bianco, nero
Adjustable fins in aluminium, white, black



TABULA



TABULA PAR 38

DESCRIZIONE: Proiettore in alluminio orientabile, da binario e superficie.
Sorgente LED 230V E27.
Non necessita di alimentatore.

DESCRIPTION: Adjustable aluminium projector for track and surface. LED source 230V E27. No power supply needed.

DIMENSIONI:

DIMENSIONS:

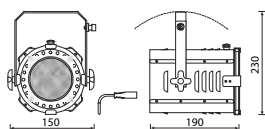

FINITURE: Alluminio naturale, nero opaco, bianco lucido.

FINISHES: Natural aluminum, matte black, glossy white.

ACCESSORI: DEF, KBM1, KPP/S, KPT, PZ-230, CSK, XTSAF, XTSAF-PG

ACCESSORIES:



TABULA PAR 30

DESCRIZIONE: Proiettore in alluminio orientabile, da binario e superficie.
Sorgente LED 230V E27.
Non necessita di alimentatore.

DESCRIPTION: Adjustable aluminium projector for track and surface. LED source 230V E27. No power supply needed.

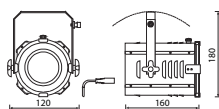

FINITURE: Alluminio naturale, nero opaco, bianco lucido.

FINISHES: Natural aluminum, matte black, glossy white.

ACCESSORI: DEF2, KBM2, PPK/S, TPK, CSK, PZ-230, XTSAF, XTSAF-PP

ACCESSORIES:



TABULA PAR 16

DESCRIZIONE: Proiettore in alluminio orientabile, da binario e superficie.
Sorgente LED 230V GU10.
Non necessita di alimentatore.

DESCRIPTION: Adjustable aluminium projector for track and surface. LED source 230V GU10. No power supply needed.

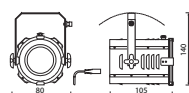

FINITURE: Alluminio naturale, nero opaco, bianco lucido.

FINISHES: Natural aluminum, matte black, glossy white.

ACCESSORI: DEF3, CSK, KBM3, PPK/S, TPK, XTSAF, XTSAF-PP

ACCESSORIES:

LED PAR 38 120 30° 14W E27

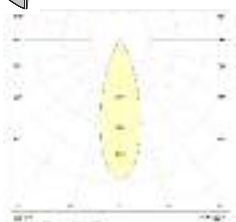

LED PAR 30 90 30° 9W E27

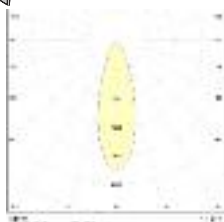

LED GU10 80 36° 7W GU10

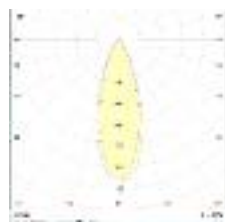

Caratteristiche tecniche lampadina/ Bulb technical data

	PAR38 led	PAR30 led	PAR16 led
Code	PAR38 led	PAR30 led	PAR16 led
Power	14W	9 W	6,7W
Flux	1035lm	766lm	575lm
Kelvin	2700K/3000K	2700K/3000K	3000K
Beam	30°	30°	36°
Dimensions	h135xØ121 mm	h96xØ92 mm	h58x Ø49,6 mm
Int. protection	IP20	IP20	IP20
Energy efficiency	A+	A+	A+



CSK L MAX 250CM
Cablaggio 3x0,75 con spina Schuko e connettore
Wiring 3x0,75 with Schuko plug and connector



KBM1 Ø120MM
Base di alluminio con cavo e connettore
Base supplied with wire and connector



KBM2 Ø88MM
Base di alluminio con cavo e connettore
Base supplied with wire and connector



KBM3 Ø58MM
Base di alluminio con cavo e connettore
Base supplied with wire and connector











**Mitico, proiettore in alluminio fortemente ispirato al set cinematografico, ridefinisce la relazione fra luce, architettura e design.
Mitico è equipaggiabile con diverse sorgenti luminose ed è disponibile in alluminio naturale, alluminio/nero, alluminio/bianco.**

Mitico, projector in aluminum strongly inspired by the movie set, redefining the relationship between light, architecture and design.
Mitico is equipped with various light sources, and it is available in natural aluminium, aluminium/black or aluminium/white.

MITICO



DESCRIZIONE: Proiettore da pavimento in alluminio e ferro naturale cerato.
Sorgente LED 230V E27.
Non necessita di alimentatore.

DESCRIPTIONS: Aluminium and waxed iron floor projector.
LED source 230V E27.
No power supply needed.

FINITURE: Alluminio naturale e ferro naturale cerato.

FINISHES: Natural aluminum and waxed iron.

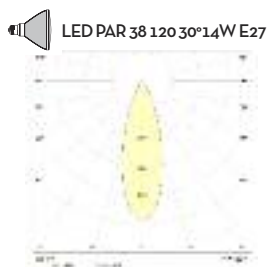

Caratteristiche tecniche lampadina/ Bulb technical data

Code	PAR38 led
Power	14W
Flux	1035lm
Kelvin	2700K/3000K
Beam	30°
Dimensions	h135xØ121 mm
Int. protection	IP20
Energy efficiency	A+

DIMENSIONI:

DIMENSIONS:

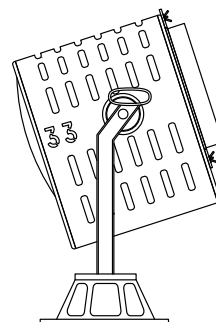
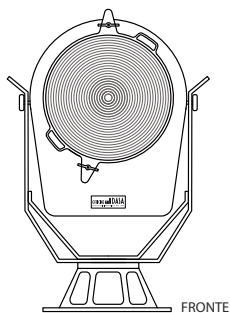
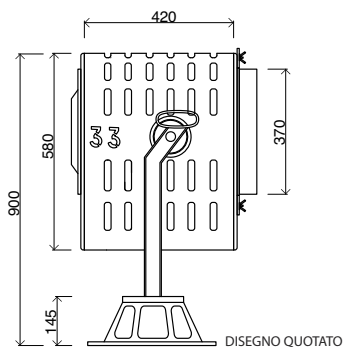



MITICO



MITICO 4000



MITICO 3000



MITICO 2000

DESCRIZIONE:	Proiettore in alluminio orientabile, da binario e superficie. Sorgente LED con driver incorporato, non direttamente sostituibile.	Proiettore in alluminio orientabile, da binario e superficie. Sorgente LED con driver incorporato, non direttamente sostituibile.	Proiettore in alluminio orientabile, da binario e superficie. Sorgente LED con driver incorporato, non direttamente sostituibile.
DESCRIPTIONS:	Adjustable aluminium projector for track and surface. Led source with driver on board not directly replaceable.	Adjustable aluminium projector for track and surface. Led source with driver on board not directly replaceable.	Adjustable aluminium projector for track and surface. Led source with driver on board not directly replaceable.
DIMENSIONI:			
FINITURE:	Alluminio e ferro naturale, alluminio e bianco, alluminio e nero.	Alluminio e ferro naturale, alluminio e bianco, alluminio e nero.	Alluminio e ferro naturale, alluminio e bianco, alluminio e nero.
FINISHES:	Aluminium and natural iron, aluminium and white, aluminium and black.	Aluminium and natural iron, aluminium and white, aluminium and black.	Aluminium and natural iron, aluminium and white, aluminium and black.
ACCESSORI:	DEFM, CSK, KBM1, KPP/S, KPT, PZ-230, XTSAF, XTSAF-PG	DEFM, CSK, KBM1, KPP/S, KPT, PZ-230, XTSAF, XTSAF-PG	DEFM, CSK, KBM1, KPP/S, KPT, PZ-230, XTSAF, XTSAF-PG
ACCESSORIES:			

Tutti i fari sono disponibili con due differenti angoli del fascio luminoso: 18° o 36°

CRI > 90 classe 1A

All the spots are available with two different beam angles: 18° or 36°

CRI > 90 1A class

Caratteristiche tecniche/Technical data

Code	4/18	4/36	3/18	3/36	2/18	2/36
Power	34,9W	34,9W	27W	27W	18,6W	18,6W
Flux	3800lm	3800lm	3000lm	3000lm	2310lm	2310lm
Kelvin	3000K	3000K	3000K	3000K	3000K	3000K
Beam	18°	36°	18°	36°	18°	36°
Efficacy	109lm/W	109lm/W	111lm/W	111lm/W	124lm/W	124lm/W
Int. protection	IP20	IP20	IP20	IP20	IP20	IP20
Energy efficiency	A+	A+	A+	A+	A+	A+

18°

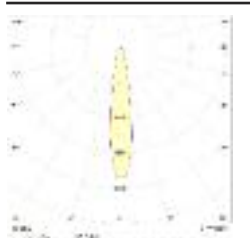

36°

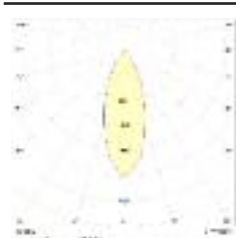

DEFM 330X330MM
Deflettore in alluminio naturale, bianco, nero
Adjustable fins in aluminium, white, black



DEFM2 220X220MM
Deflettore in alluminio naturale, bianco, nero
Adjustable fins in aluminium, white, black



DEFM3 150X150MM
Deflettore in alluminio naturale, bianco, nero
Adjustable fins in aluminium, white, black



KPP/S 250X200+1000MM
Pantografo in acciaio zincato, cavo o spina Schuko
Galvanized steel pantograph, wire and Schuko plug



MITICO



MITICO PAR 38

DESCRIZIONE: Proiettore in alluminio orientabile, da binario e superficie.
Sorgente LED 230V E27.
Non necessita di alimentatore.

DESCRIPTIONS: Adjustable aluminium projector for track and surface. LED source 230V E27. No power supply needed.

DIMENSIONI:
DIMENSIONS:

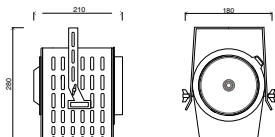

MITICO PAR 30

DESCRIZIONE: Proiettore in alluminio orientabile, da binario e superficie.
Sorgente LED 230V E27.
Non necessita di alimentatore.

DESCRIPTIONS: Adjustable aluminium projector for track and surface. LED source 230V E27. No power supply needed.

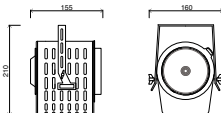

MITICO PAR 16

DESCRIZIONE: Proiettore in alluminio orientabile, da binario e superficie.
Sorgente LED 230V GU10.
Non necessita di alimentatore.

DESCRIPTIONS: Adjustable aluminium projector for track and surface. LED source 230V GU10. No power supply needed.

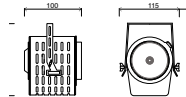

FINITURE: Alluminio naturale, nero opaco, bianco lucido.

FINISHES: Natural aluminum, matte black, glossy white.

ACCESSORI: DEFM, KBM1, KPP/S, KPT, PZ-230, CSK, XTSAF, XTSAF-PG

ACCESSORIES:

FINITURE: Alluminio naturale, nero opaco, bianco lucido.

FINISHES: Natural aluminum, matte black, glossy white.

ACCESSORI: DEFM2, KBM2, PPK/S, TPK, CSK, PZ-230, XTSAF, XTSAF-PP

ACCESSORIES:

FINITURE: Alluminio naturale, nero opaco, bianco lucido.

FINISHES: Natural aluminum, matte black, glossy white.

ACCESSORI: DEFM3, CSK, KBM3, PPK/S, TPK, XTSAF, XTSAF-PG

ACCESSORIES:

LED PAR 38 120 30° 14W E27

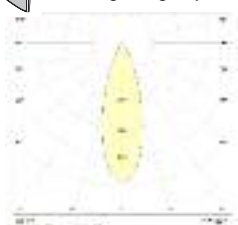

LED PAR 30 90 30° 9W E27

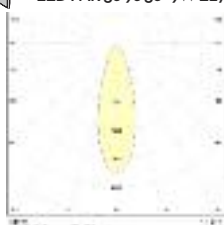

LED GU10 80 36° 7W GU10

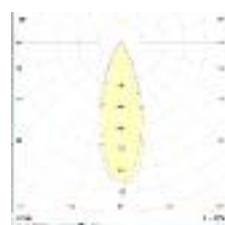

Caratteristiche tecniche lampadina/ Bulb technical data

Code	PAR38 led	PAR30 led	PAR16 led
Power	14W	9 W	6,7W
Flux	1035lm	766lm	575lm
Kelvin	2700K/3000K	2700K/3000K	3000K
Beam	30°	30°	36°
Dimensions	h135xØ121 mm	h96xØ92 mm	h58x Ø49,6 mm
Int. protection	IP20	IP20	IP20
Energy efficiency	A+	A+	A+



CSK L MAX 250CM
Cablaggio 3x0,75 con spina Schuko e connettore
Wiring 3x0,75 with Schuko plug and connector



KBM1 Ø120MM
Base di alluminio con cavo e connettore
Base supplied with wire and connector



KBM2 Ø88MM
Base di alluminio con cavo e connettore
Base supplied with wire and connector



KBM3 Ø58MM
Base di alluminio con cavo e connettore
Base supplied with wire and connector





CUBETTO



Cubetto proiettore da binario crea una luce funzionale catturandola in forma geometrica fortemente definita. Il corpo dell'apparecchio è realizzato in ferro nero lasciato al naturale e cerato a mano o nella versione verniciata bianco lucido. Le diverse tipologie di montaggio consentono molteplici applicazioni.

Cubetto spot for track wants to create functional light captured in a small box, a geometric shape strongly defined. The body is made in black iron left natural and waxed by hand or in the painted glossy white version. The different types of mounting allow multiple applications.

CUBETTO



CUBETTO B301



CUBETTO B161

DESCRIZIONE: Proiettore orientabile da binario in metallo.
Sorgente LED 230V E27.
Non necessita di alimentatore.

DESCRIZIONE: Proiettore orientabile da binario in metallo.
Sorgente LED 230V GU10.
Non necessita di alimentatore.

DESCRIPTION: Adjustable metal projector for track.
LED source 230V E27. No power supply needed.

DESCRIPTION: Adjustable metal projector for track.
LED source 230V GU10. No power supply needed.

DIMENSIONI:
DIMENSIONS:

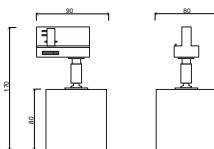
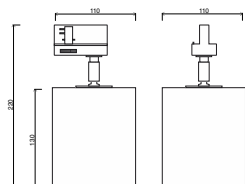

FINITURE: Ferro naturale cerato, bianco lucido.

FINITURE: Ferro naturale cerato, bianco lucido.

FINISHES: Ferro naturale cerato, glossy white.

FINISHES: Ferro naturale cerato, glossy white.

 LED PAR 30 90 30° 9W E27

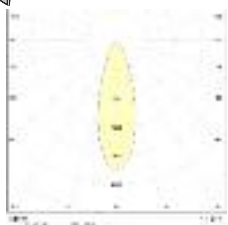

 LED GU10 80 36° 7W GU10

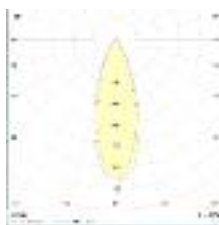

Caratteristiche tecniche lampadina/ Bulb technical data

	PAR30 led	PAR16 led
Code	PAR30 led	PAR16 led
Power	9 W	6,7W
Flux	766lm	575lm
Kelvin	2700K/3000K	3000K
Beam	30°	36°
Dimensions	h96xØ92 mm	h58x Ø49,6 mm
Int. protection	IP20	IP20
Energy efficiency	A+	A+



CUBETTO



CUBETTO B301/F

DESCRIZIONE: Proiettore orientabile da binario in metallo.
Sorgente LED 230V E27.
Non necessita di alimentatore.

DESCRIPTION: Adjustable metal projector for track.
LED source 230V E27. No power supply needed.

DIMENSIONI:
DIMENSIONS:

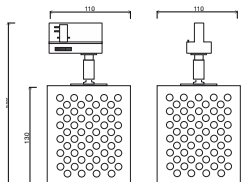

FINITURE: Ferro naturale cerato, bianco lucido.

FINISHES: Ferro naturale cerato, glossy white.



CUBETTO B161/F

DESCRIZIONE: Proiettore orientabile da binario in metallo.
Sorgente LED 230V GU10.
Non necessita di alimentatore.

DESCRIPTION: Adjustable metal projector for track.
LED source 230V GU10. No power supply needed.

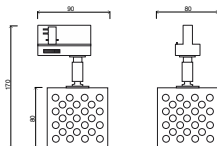

FINITURE: Ferro naturale cerato, bianco lucido.

FINISHES: Ferro naturale cerato, glossy white.

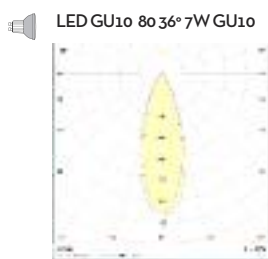
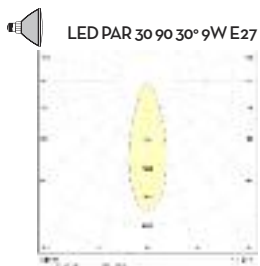

Caratteristiche tecniche lampadina/ Bulb technical data

	PAR30 led	PAR16 led
Code	PAR30 led	PAR16 led
Power	9 W	6,7W
Flux	766lm	575lm
Kelvin	2700K/3000K	3000K
Beam	30°	36°
Dimensions	h96xØ92 mm	h58x Ø49,6 mm
Int. protection	IP20	IP20
Energy efficiency	A+	A+







SOSPENSIONI
SUSPENSIONS

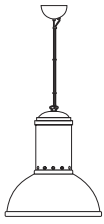

VITTORIA



LISA



CLARA

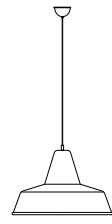

URBANA



BETTA

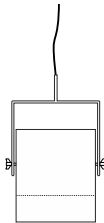

GAIA



OLIVIA

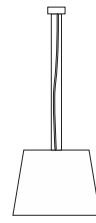

GINA

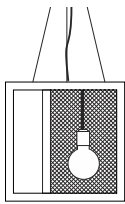

EVA

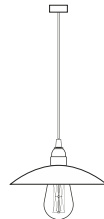

PEPE



ZOE

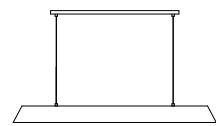

OPERA



FLAPLIGHT





Lo stile di questa sospensione rievoca le lampade industriali utilizzate nelle fabbriche e nei magazzini di tutto il mondo. Reinventata in uno stile contemporaneo, "Vittoria" conferisce agli ambienti in cui si colloca una dimensione extratemporale.

The style of this suspension recalls the industrial lamps used in factories and warehouses around the world. Reinvented in a contemporary style, it can be transferred in the context in which it appears a timeless dimension.

VITTORIA XS



VITTORIA XS-2000

DESCRIZIONE: Sospensione in alluminio, parabola riflettente tirante in acciaio. Sorgente Led 230V AC. A richiesta 3000/4000 lm.

DESCRIPTION: Suspension in aluminium, high efficiency reflector, steel tie. Led source direct main connection 230V AC. On demand 3000/4000 lm.

DIMENSIONI:
DIMENSIONS:

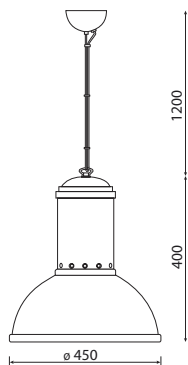

VITTORIA XS-AL

DESCRIZIONE: Sospensione in alluminio, parabola riflettente tirante in acciaio. Sorgente LED 230V E27. A richiesta 3000/4000 lm.

DESCRIPTION: Suspension in aluminium, high efficiency reflector, steel tie. LED source, 230V E27. On demand 3000/4000 lm.

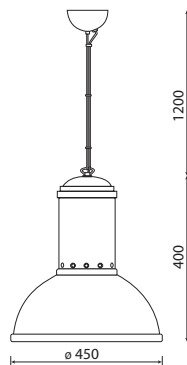

APPLICAZIONI: Adatto per l'illuminazione di ambienti commerciali, showroom e uffici.

APPLICATIONS: Suitable for commercial lighting, showroom and office.

FINITURE: Alluminio naturale, nero, bianco.

FINISHES: Natural aluminum, black, white.

Adatto per l'illuminazione di ambienti commerciali e residenziali.

Suitable for commercial and residential lighting.

Alluminio naturale, nero, bianco.

Natural aluminum, black, white.

Caratteristiche tecniche lampadina
Bulb technical data

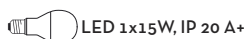

Power	20 W
Flux	1800 lm
Kelvin	3000K
Beam	120°
Int. protection	IP20
Energy efficiency	A+
CRI	90

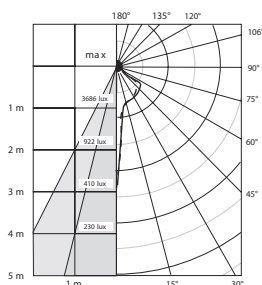



VITTORIA XL



VITTORIA XL-2000

DESCRIZIONE: Sospensione in alluminio, parabola riflettente tirante in acciaio. Sorgente Led 230V AC. A richiesta 3000/4000 lm.

DESCRIPTION: Suspension in aluminium, high efficiency reflector, steel tie. Led source direct main connection 230V AC. On demand 3000/4000 lm.

DIMENSIONI:
DIMENSIONS:

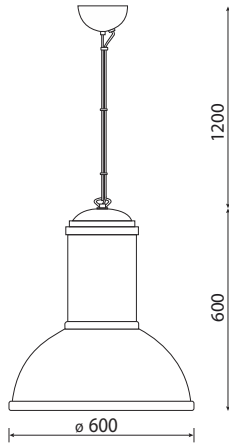

APPLICAZIONI: Adatto per l'illuminazione di ambienti commerciali, showroom e uffici.

APPLICATIONS: Suitable for commercial lighting, showroom and office.

FINITURE: Alluminio naturale, nero, bianco.

FINISHES: Natural aluminum, black, white.



VITTORIA XL-AL

DESCRIZIONE: Sospensione in alluminio, parabola riflettente tirante in acciaio. Sorgente LED 230V E27. A richiesta 3000/4000 lm.

DESCRIPTION: Suspension in aluminium, high efficiency reflector, steel tie. LED source, 230V E27. On demand 3000/4000 lm.

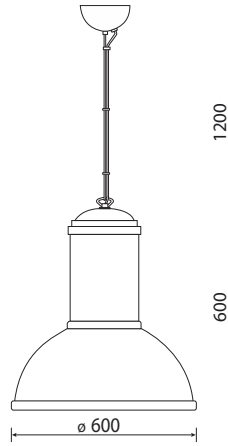

APPLICAZIONI: Adatto per l'illuminazione di ambienti commerciali e residenziali.

APPLICATIONS: Suitable for commercial and residential lighting.

FINITURE: Alluminio naturale, nero, bianco.

FINISHES: Natural aluminum, black, white.

Caratteristiche tecniche lampadina
Bulb technical data

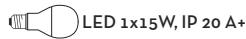

Power	20 W
Flux	1800 lm
Kelvin	3000K
Beam	120°
Int. protection	IP20
Energy efficiency	A+
CRI	90

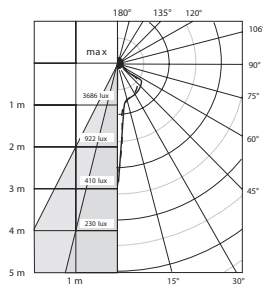











Un grande cappello di alluminio tornito fa da cornice a questa sospensione dalle grandi dimensioni. Vintage nell'ispirazione ma contemporanea nella realizzazione questa lampada è un chiaro ed inequivocabile riferimento agli ambienti industriali.

A big hat in aluminum makes frame to this large suspension. Vintage inspiration but contemporary creation, a clear reference to industrial environments.

LISA



LISA-2000

DESCRIZIONE: Sospensione in alluminio, parabola riflettente tirante in acciaio. Sorgente Led 230V AC.

DESCRIPTION: Suspension in aluminium, high efficiency reflector, steel tie. Led source direct main connection 230V AC.

DIMENSIONI:
DIMENSIONS:

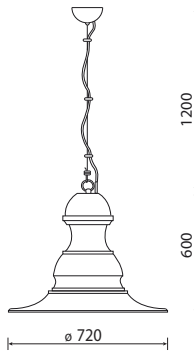

LISA-AL

DESCRIZIONE: Sospensione in alluminio, parabola riflettente tirante in acciaio. Sorgente LED 230V E27.

DESCRIPTION: Suspension in aluminium, high efficiency reflector, steel tie. LED source, 230V E27.

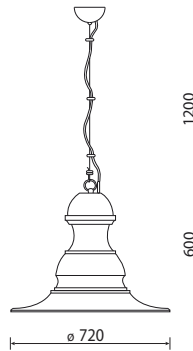

APPLICAZIONI: Adatto per l'illuminazione di ambienti commerciali, showroom e uffici.

APPLICATIONS: Suitable for commercial lighting, showroom and office.

FINITURE: Alluminio naturale, nero, bianco.

FINISHES: Natural aluminum, black, white.

Adatto per l'illuminazione di ambienti commerciali e residenziali.

Suitable for commercial and residential lighting.

Alluminio naturale, nero, bianco.

Natural aluminum, black, white.

Caratteristiche tecniche lampadina
Bulb technical data

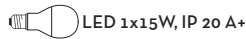

Power	20 W
Flux	1800 lm
Kelvin	3000K
Beam	120°
Int. protection	IP20
Energy efficiency	A+
CRI	90

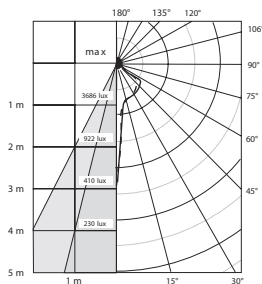









CLARA



Le linee morbide di questa lampada definiscono una nuova armonia tra luce ed architettura. Realizzata in tornito di alluminio questa sospensione può essere fornita con attacco E27 o con tecnologia LED.

The soft lines of this lamp aims to create harmony between light and architecture. Realized in turned aluminium this suspension is available with E27 connection or LED technology.

CLARA



CLARA-2000

DESCRIZIONE: Sospensione in alluminio, parabola riflettente tirante in acciaio. Sorgente Led 230V AC.

DESCRIPTION: Suspension in aluminium, high efficiency reflector, steel tie. Led source direct main connection 230V AC.

DIMENSIONI:

DIMENSIONS:

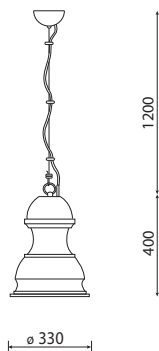

CLARA-AL

DESCRIZIONE: Sospensione in alluminio, parabola riflettente tirante in acciaio. Sorgente LED 230V E27.

DESCRIPTION: Suspension in aluminium, high efficiency reflector, steel tie. LED source, 230V E27.

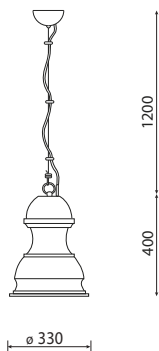

APPLICAZIONI: Adatto per l'illuminazione di ambienti commerciali, showroom e uffici.

APPLICATIONS: Suitable for commercial lighting, showroom and office.

FINITURE: Alluminio naturale, nero, bianco.

FINISHES: Natural aluminum, black, white.

Adatto per l'illuminazione di ambienti commerciali e residenziali.

Suitable for commercial and residential lighting.

Alluminio naturale, nero, bianco.

Natural aluminum, black, white.

Caratteristiche tecniche lampadina
Bulb technical data



Power	20 W
Flux	1800 lm
Kelvin	3000K
Beam	120°
Int. protection	IP20
Energy efficiency	A+
CRI	90

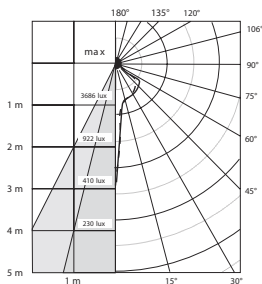











Elegante nella sua semplicità Urbana riprende l'immagine familiare delle lampade industriali, un design senza tempo.

Realizzata in alluminio tornito, l'interno bianco permette alle luce di riflettere e di dirigersi completamente verso il basso. Una griglia di metallo a protezione della parte elettrica diventa un elemento decorativo.

Elegant in its simplicity Urbana takes the familiar image of industrial lamps.

Realized in turned aluminium, the white reflector allow a light to the down. A metal protection grid becomes a decorative element.

URBANA



URBANA

DESCRIZIONE: Sospensione in alluminio, con parabola riflettente.
LED 230V E27.

DESCRIPTION: Suspension in aluminium with high efficiency reflector.
LED 230V E27.

DIMENSIONI:
DIMENSIONS:

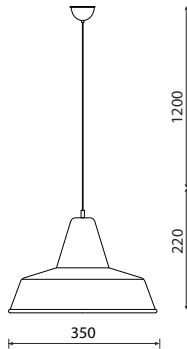

APPLICAZIONI: Adatto per l'illuminazione di ambienti commerciali e residenziali.

APPLICATIONS: Suitable for commercial and residential lighting.

FINITURE: Alluminio naturale, nero, bianco.

FINISHES: Natural aluminum, black, white.

LAMPADINA:  LED 1x15W, IP 20 A+
BULB:

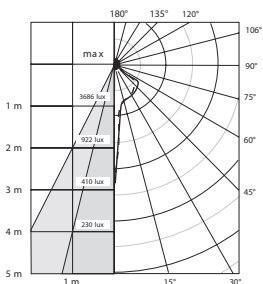











Betta, lampada a sospensione dalla grande presenza, è realizzata in ferro nero cerato a mano. Un pannello in opale fa filtrare, verso il basso, una luce diffusa e non abbagliante.

Due dimensioni per questa lampada che racchiude tutto il fascino industriale del metallo.

Betta, hanging lamp from the large presence, is made of black natural iron, waxed by hand. A panel in opal filter down a diffuse and glare light.

Two dimensions for this lamp which contains all metal industrial charm.

BETTA



BETTA 50

DESCRIZIONE: Sospensione in ferro nero naturale cerato con schermo diffusore in polipropilene, tiranti in acciaio. Sorgente LED con driver incorporato, non direttamente sostituibile.

DESCRIPTION: Ceiling lamp in natural black iron waxed, with polypropylene diffuser screen. LED source with driver on board. Not direct replace.

DIMENSIONI:
DIMENSIONS:

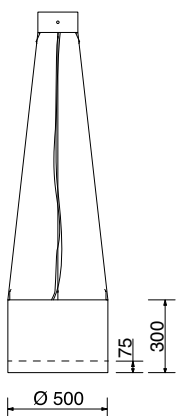

APPLICAZIONI: Adatto per l'illuminazione di ambienti commerciali e residenziali.

APPLICATIONS: Suitable for commercial and residential lighting.

FINITURE: Ferro naturale cerato.

FINISHES: Natural iron waxed.

LAMPADINA: LED 2000lm - 3000k - IP20 - A+
BULB:



BETTA 70

Sospensione in ferro nero naturale cerato con schermo diffusore in polipropilene, tiranti in acciaio. Sorgente LED con driver incorporato, non direttamente sostituibile.

Ceiling lamp in natural black iron waxed, with polypropylene diffuser screen. LED source with driver on board. Not direct replace.

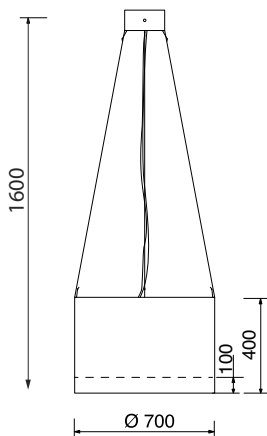

Adatto per l'illuminazione di ambienti commerciali e residenziali.

Suitable for commercial and residential lighting.

Ferro naturale cerato.

Natural iron waxed.

LED 3000lm - 3000k - IP20 - A+











La sospensione Gaia possiede uno stile moderno e giocoso dato dalla composizione del cilindro in ferro che può essere realizzato in lamiera piena o forata, e dal manico in ferro naturale che permette di orientare la luce con estrema flessibilità. Due le finiture con particolare effetto Soft Touch.

Suspension Gaia has a modern and playful style given by the composition of the cylinder iron that can be made of solid sheet metal or perforated, and the iron handle which allows natural light to the east with extreme flexibility. Two finishes with particular effect Soft Touch.

GAIA



GAIA 3035

DESCRIZIONE: Sospensione in ferro laccato, tirante in acciaio attacco sorgente LED 230V attacco E27.

DESCRIPTION: Suspension in iron lacquered, steel tie, LED 230V, E27.

DIMENSIONI:
DIMENSIONS:

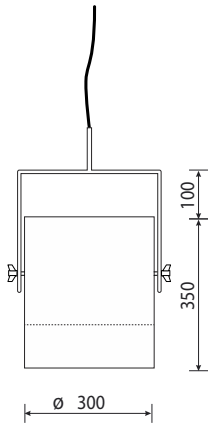

APPLICAZIONI: Adatto per l'illuminazione di ambienti commerciali e residenziali.

APPLICATIONS: Suitable for commercial and residential lighting.

FINITURE: Grigio cemento, rosso.

FINISHES: Cement grey, red.

LAMPADINA:  LED 15W, IP 20 A+

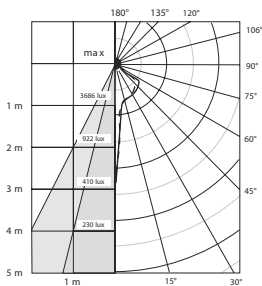

GAIA 1550

Sospensione in ferro laccato, tirante in acciaio attacco sorgente LED 230V attacco E27.

Suspension in iron lacquered, steel tie, LED 230V, E27.

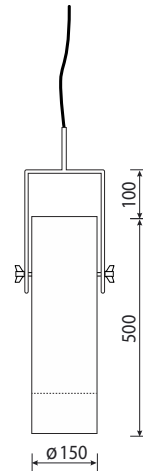

Adatto per l'illuminazione di ambienti commerciali e residenziali.

Suitable for commercial and residential lighting.

Grigio cemento, rosso.

Cement grey, red.

LAMPADINA:  LED 15W, IP 20 A+

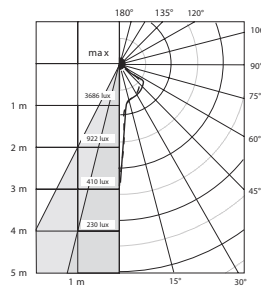



GAIA



GAIA 3035-F

DESCRIZIONE: Sospensione in ferro laccato, tirante in acciaio attacco sorgente LED 230V attacco E27.

DESCRIPTION: Suspension in iron lacquered, steel tie, LED 230V, E27.

DIMENSIONI:

DIMENSIONS:

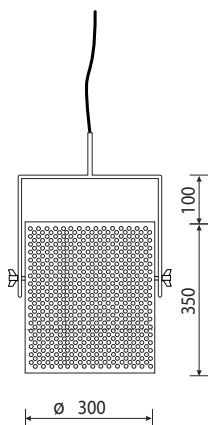

APPLICAZIONI: Adatto per l'illuminazione di ambienti commerciali e residenziali.

APPLICATIONS: Suitable for commercial and residential lighting.

FINITURE: Grigio cemento, rosso.

FINISHES: Cement grey, red.

LAMPADINA:

BULB:



LED 15W, IP 20 A+

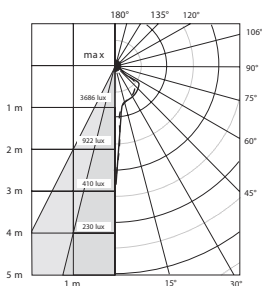

GAIA 1550-F

Sospensione in ferro laccato, tirante in acciaio attacco sorgente LED 230V attacco E27.

Suspension in iron lacquered, steel tie, LED 230V, E27.

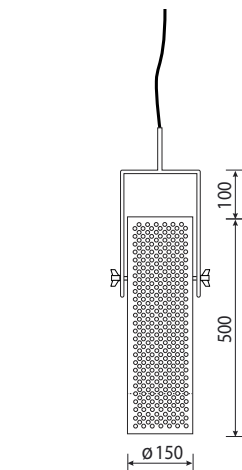

Adatto per l'illuminazione di ambienti commerciali e residenziali.

Suitable for commercial and residential lighting.

Grigio cemento, rosso.

Cement grey, red.



LED 15W, IP 20 A+

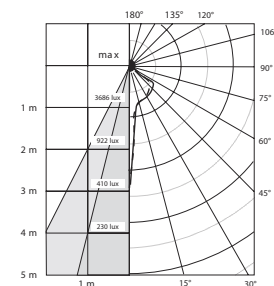









OLIVIA



L'ispirazione all'archeologia industriale di Olivia è pienamente percepibile in questa sospensione, realizzata con un tubo in ferro nero naturale cerato a mano. Dotata di una lampadina LED GU10, permette una luce puntuale in grado di dar vita ad un'atmosfera minimalista. Disponibile in due lunghezze per favorire la realizzazione di accattivanti composizioni dinamiche.

Olivia is a suspension of industrial inspiration. Made with steel black pipe, waxed by hand. Equipped with led retrofit GU10, allows exact light that a minimalist view. Available in two lengths that allow a dynamic composition.

OLIVIA



OLIVIA 70



OLIVIA 100

DESCRIZIONE: Sospensione in ferro naturale con tirante in acciaio. Attacco LED GU10.

DESCRIPTION: Suspension in black natural iron, steel tie, LED GU10.

DESCRIZIONE: Sospensione in ferro naturale con tirante in acciaio. Attacco LED GU10.

DESCRIPTION: Suspension in black natural iron, steel tie, LED GU10.

DIMENSIONI:
DIMENSIONS:

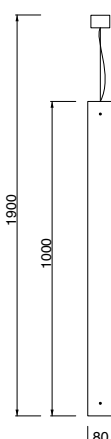
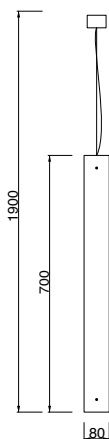

APPLICAZIONI: Adatto per l'illuminazione di ambienti commerciali e residenziali.

APPLICATIONS: Suitable for commercial and residential lighting.

APPLICAZIONI: Adatto per l'illuminazione di ambienti commerciali e residenziali.

APPLICATIONS: Suitable for commercial and residential lighting.

FINITURE: Ferro naturale cerato.

FINISHES: Natural iron waxed.

FINITURE: Ferro naturale cerato.

FINISHES: Natural iron waxed.

LAMPADINA:  **LED 7W GU10 230V (resa 50W)**

LAMPADINA:  **LED 7W GU10 230V (resa 50W)**

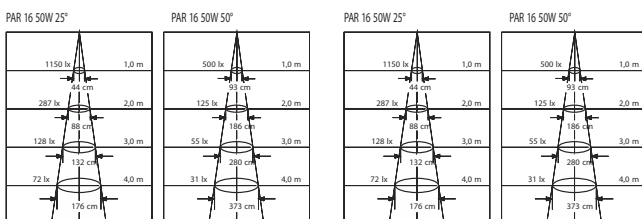











Sospensione in stile metropolitano con design dalle forme geometriche. Silhouette ridotta e lineare, si inserisce bene in contesti differenti, spaziando dagli uffici alle residenze e perfino nel retail.

Suspension lamp in metropolitan style with geometric design. The Silhouette reduced and linear design fits it well in different contexts, offices, residences and retail

GINA



GINA

DESCRIZIONE: Realizzata in ferro nero naturale cerato a mano, equipaggiata con n. 2 lampade attacco E27.

DESCRIPTION: Realized in black natural iron waxed by hand, n. 2 bulbs E27.

DIMENSIONI: 400 x 400 x H300 mm (cavo H1200)

DIMENSIONS:

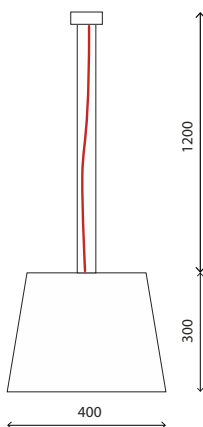

APPLICAZIONI: Adatto per l'illuminazione di ambienti commerciali e residenziali.

APPLICATIONS: Suitable for commercial and residential lighting.

FINITURE: Ferro naturale cerato.

FINISHES: Natural iron waxed.

LAMPADINA:  Carbonfilament E27 40W - IP20 - D

BULB:  Carbonfilament E27 40W - IP20 - D

 LED E27 - 9W =60W - IP20 - A+





EVA



La lanterna EVA richiama un passato non troppo lontano quando la luce aveva un sapore caldo, soffuso e quasi magico. Eva è realizzata in ferro naturale, aperta su tre lati e uno chiuso da una rete che offre un effetto giocoso di luci ed ombre.

The lantern EVA recalls a not so distant past where the light had a taste of warm, suffused and almost magical. Eva is made of natural iron, open on three sides and one closed by a grid that offers a playful effect to the light.

EVA



EVA 6060

DESCRIZIONE: Sospensione in ferro naturale cerato, tiranti in acciaio, attacco E27.

DESCRIPTION: Suspension in iron lacquered, steel tie, E27.

DIMENSIONI: 600 x 600 x H600 mm (cavo H1200)

DIMENSION:

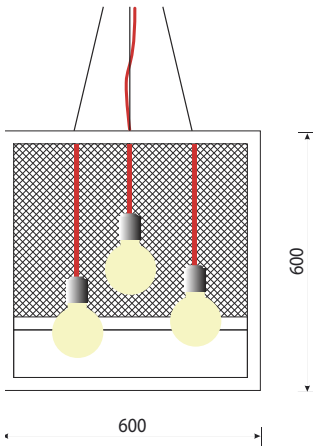

EVA 4545

DESCRIZIONE: Sospensione in ferro naturale cerato, tiranti in acciaio, attacco E27.

DESCRIPTION: Suspension in iron lacquered, steel tie, E27.

DIMENSIONI: 450 x 300 x H450 mm (cavo H1200)

DIMENSION:

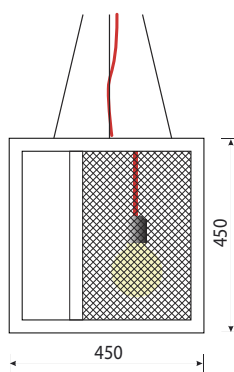

EVA 3060

DESCRIZIONE: Sospensione in ferro naturale cerato, tiranti in acciaio, attacco E27.

DESCRIPTION: Suspension in iron lacquered, steel tie, E27.

DIMENSIONI: 300 x 300 x H 600 mm (cavo H1200)

DIMENSION:

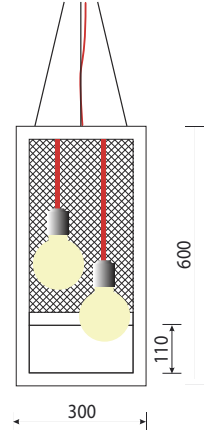



APPLICAZIONI: Adatto per l'illuminazione di ambienti commerciali e residenziali.

APPLICATIONS: Suitable for commercial and residential lighting.

FINITURE: Ferro naturale cerato.

FINISHES: Natural iron waxed.

LAMPADINA:   (3x)
BULB: Carbonfilament E27 40W - IP20 - D

 
LED E27 - 9W =60W - IP20 - A+

APPLICAZIONI: Adatto per l'illuminazione di ambienti commerciali e residenziali.

APPLICATIONS: Suitable for commercial and residential lighting.

FINITURE: Ferro naturale cerato.

FINISHES: Natural iron waxed.

LAMPADINA:   (1x)
BULB: Carbonfilament E27 40W - IP20 - D

LED E27 - 9W =60W - IP20 - A+

APPLICAZIONI: Adatto per l'illuminazione di ambienti commerciali e residenziali.

APPLICATIONS: Suitable for commercial and residential lighting.

FINITURE: Ferro naturale cerato.

FINISHES: Natural iron waxed.

LAMPADINA:   (2x)
BULB: Carbonfilament E27 40W - IP20 - D

LED E27 - 9W =60W - IP20 - A+





PEPE



**Lampada dal design senza tempo, la piccola Pepe sposa equilibrio e leggerezza poiché prodotta in alluminio laccato con interno metallizzato riflettente, per creare un'illuminazione calda e intensa.
Disponibile nella versione a sospensione e per binario.**

Lamp from the timeless design, the small Pepe bride balance and lightness because produced in lacquered aluminum with internal metallic reflective, to create warm and intense illumination.
Available in suspension version and for track.

PEPE



PEPE

DESCRIZIONE: Sospensione in alluminio laccato, attacco E27.

DESCRIPTION: Suspension in lacquered aluminium, E27.

DIMENSIONI:
DIMENSIONS:

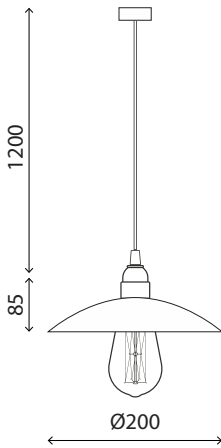

APPLICAZIONI: Adatto per l'illuminazione di ambienti commerciali e residenziali.

APPLICATIONS: Suitable for commercial and residential lighting.

FINITURE: Nero.

FINISHES: Black.

LAMPADINA:
BULB:



Carbonfilament E27 40W - IP20 - D



LED E27 - 9W = 60W - IP20 - A+



PEPE BIN

Lampada a binario in alluminio laccato, attacco E27.

Track lamp in lacquered aluminium, E27.

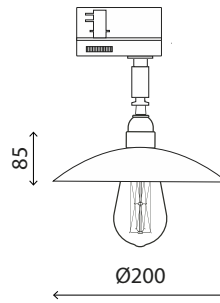

Adatto per l'illuminazione di ambienti commerciali e residenziali.

Suitable for commercial and residential lighting.

Nero.

Black.



Carbonfilament E27 40W - IP20 - D



LED E27 - 9W = 60W - IP20 - A+







Sospensione in alluminio tornito dal design singolare, la lampada Zoe ha una personalità semplice ed elegante ed è in grado di inserirsi facilmente in contesti architettonici più svariati.

Small aluminum suspension from singular design, the Zoe lamp has a simple and elegant personality and it is able to easily insert into the most varied architectural contexts.

ZOE



ZOE

DESCRIZIONE: Sospensione in alluminio, attacco E27.

DESCRIPTION: Aluminium suspension, E27.

DIMENSIONI:

DIMENSIONS:

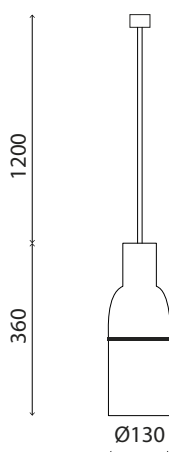

APPLICAZIONI: Adatto per l'illuminazione di ambienti commerciali e residenziali.

APPLICATIONS: Suitable for commercial and residential lighting.

FINITURE: Alluminio. Finiture speciali su richiesta.

FINISHES: Aluminium. Special finishes on demand.

LAMPADINA:

BULB:



Carbonfilament E27 40W - IP20 - D



LED 15W, IP 20 A+









Opera è una lampada a sospensione che riprogetta il concetto di plafoniera, con un design semplice, lineare e preciso. La luce si proietta negli ambienti diffondendo un carattere concreto e duraturo che rende Opera adatta a molteplici applicazioni. Realizzata in ferro nero naturale cerato o laccato bianco, questa plafoniera è disponibile in due dimensioni e nella versione liscia e forata.

A richiesta può essere accessoriata di schermo diffusore.

Opera is a pendant lamp that designs the concept of ceiling, with a simple, straightforward and precise design. The light shines and spreads in the environments with concrete and lasting character that makes Opera suitable for many applications. Made of black iron waxed or painted white, this f is available in two sizes and in a smooth version and perforated.

On request it can be equipped with diffusing screen.

OPERA FORATA



OPERA 136F

DESCRIZIONE: Plafoniera in lamiera nera liscia o forata, adatta per tubi fluorescenti o LED

DESCRIPTION: Ceiling lamp in black natural iron, suitable for fluorescent or LED pipes.

DIMENSIONI:
DIMENSIONS:

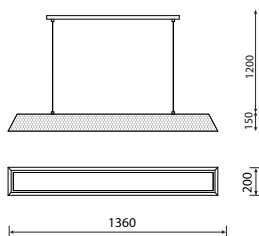

OPERA 176F

DESCRIZIONE: Plafoniera in lamiera nera liscia o forata, adatta per tubi fluorescenti o LED

DESCRIPTION: Ceiling lamp in black natural iron, suitable for fluorescent or LED pipes.

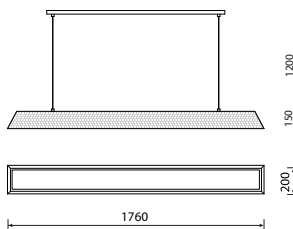

APPLICAZIONI: Adatto per l'illuminazione di uffici, residenze private e spazi commerciali.

APPLICATIONS: Suitable for office, domestic and commercial locations.

FINITURE: Bianco lucido, ferro naturale cerato.

FINISHES: Glossy white, natural iron waxed.

LAMPADINA:
BULB:

T5 - 2x28W G5 230V
Led - 2x14W 2000 lm

APPLICAZIONI: Adatto per l'illuminazione di uffici, residenze private e spazi commerciali.

APPLICATIONS: Suitable for office, domestic and commercial locations.

FINITURE: Bianco lucido, ferro naturale cerato.

FINISHES: Glossy white, natural iron waxed.

T5 - 2x35W G5 230V
Led - 2x18W 2600lm

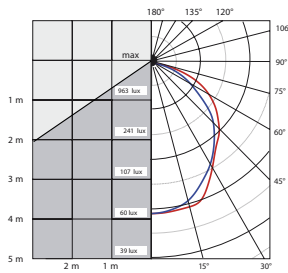
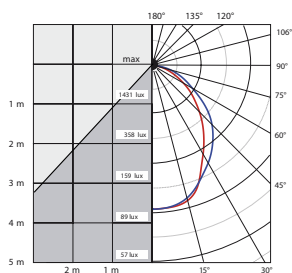



OPERA



OPERA 136

DESCRIZIONE: Plafoniera in ferro nero cerato e interno laccato, per lampade fluorescenti T5 o LED.

DESCRIPTION: Ceiling iron waxed lamp, vernish inside, for T5 fluorescent or LED lamps.



OPERA 176

DESCRIZIONE: Plafoniera in ferro nero cerato e interno laccato, per lampade fluorescenti T5 o LED.

DESCRIPTION: Ceiling iron waxed lamp, vernish inside, for T5 fluorescent or LED lamps.

DIMENSIONI:

DIMENSIONS:

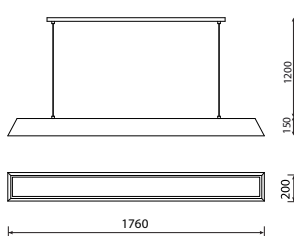
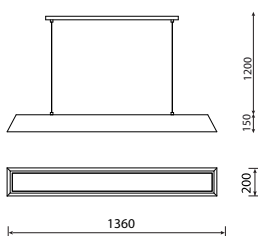

APPLICAZIONI: Adatto per l'illuminazione di uffici, residenze private e spazi commerciali.

APPLICATIONS: Suitable for commercial and residential lighting.

FINITURE: Bianco lucido, ferro naturale cerato.

FINISHES: Glossy white, natural iron waxed.

APPLICAZIONI: Adatto per l'illuminazione di uffici, residenze private e spazi commerciali.

APPLICATIONS: Suitable for commercial and residential lighting.

FINITURE: Bianco lucido, ferro naturale cerato.

FINISHES: Glossy white, natural iron waxed.

LAMPADINA:

BULB:

T5 - 2x28W G5 230V
Led - 2x14W 2000 lm

T5 - 2x35W G5 230V
Led - 2x18W 2600lm

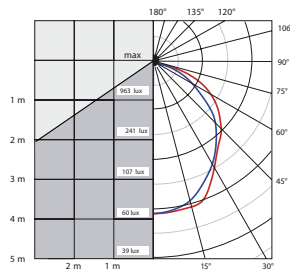
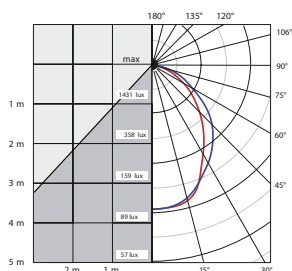









architetto marco odargi

FLAP LIGHT

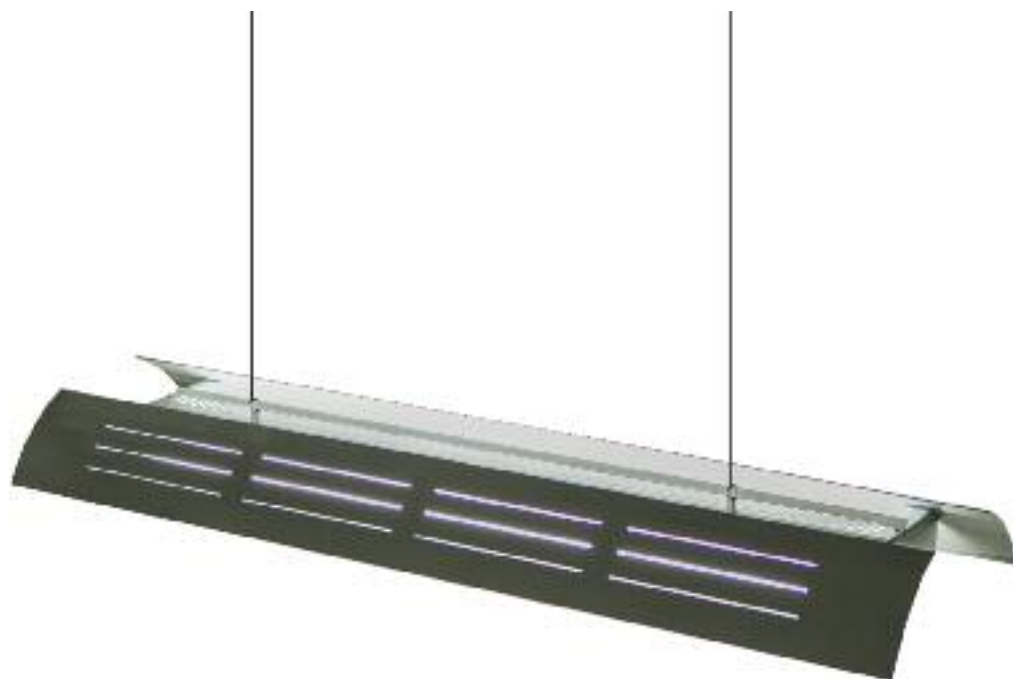

La lampada a sospensione Flap Light, progettata dall'architetto Marco Odargi, ha un design unico nel suo genere, la particolare linea della lampada ricorda il flap degli aerei e regala un senso di leggerezza e tenuità, diffondendo una luce calda ed avvolgente all'ambiente circostante. Adatta ad ambienti di grandi dimensioni, è disponibile in due misure e due tipologie di sorgenti luminose.

The pendant lamp Flap Light, designed by architect Marco Odargi, has a unique design, the particular line of the lamp reminds the flaps of the planes and gives a sense of lightness and smallness, giving a warm and enveloping light to environment surrounding. Suitable for large environments, it is available in two sizes and two types of light sources.

FLAP LIGHT



FLAP LIGHT 236

DESCRIZIONE: Plafoniera in alluminio, per tubi LED T8.

DESCRIPTION: Ceiling steel lamp, with led tubes T8.

DIMENSIONI:
DIMENSIONS:

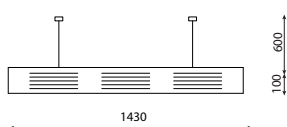

FLAP LIGHT 258

DESCRIZIONE: Plafoniera in alluminio, per tubi LED T8.

DESCRIPTION: Ceiling steel lamp, with led tubes T8.

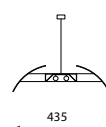
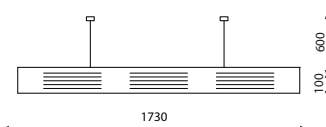

FINITURE: Alluminio satinato, bianco opaco.

FINITURE: Alluminio satinato, bianco opaco.

FINISHES: Brushed aluminum, matte white.

FINISHES: Brushed aluminum, matte white.

APPLICAZIONI: Adatto per l'illuminazione di uffici, spazi commerciali e collettivi.

APPLICAZIONI: Adatto per l'illuminazione di uffici, spazi commerciali e collettivi.

APPLICATIONS: Suitable for the lighting of offices, commercial and public spaces.

APPLICATIONS: Suitable for the lighting of offices, commercial and public spaces.

LAMPADINA:

BULB: 2x 18,4W - 2070lm - 3000K

BULB: 2x 27W - 2950lm - 3000K

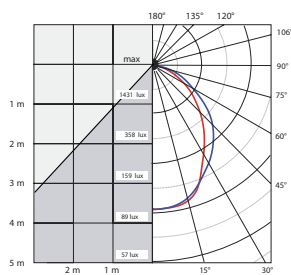
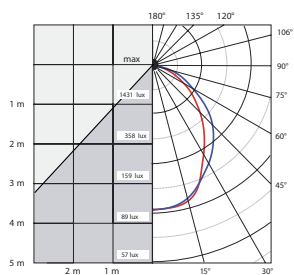







LAMPADE A PARETE
WALL LAMPS

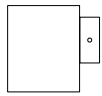

CUBETTO

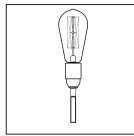

QUADRA

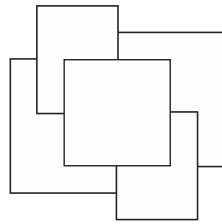

KATA



CUBETTO



Cubetto è un'appliche dalle geometrie compatte e lineari, le molteplici caratteristiche estetiche e funzionali rendono questa lampada particolarmente adatta ad essere inserita in differenti ambientazioni, relazionandosi facilmente con stili ed elementi di arredo diversi.

La struttura essenziale in ferro naturale nero cerato o laccato bianco lucido, racchiude la sorgente luminosa. Varie possibilità di utilizzo, parete, soffitto, luce diretta, indiretta, fisso, orientabile, liscio, forato. Una gamma completa per rispondere a tutte le esigenze architettoniche.

Cubetto is an applique with compact and linear geometry, the multiple and functional characteristics make this lamp highly suitable for being inserted in different environments, engaging with different styles and elements of furniture.

The essential structure in natural iron black waxed or painted glossy white, encloses the light source. Various applications, wall, ceiling, direct and indirect light, fixed, adjustable, smooth, perforated, a complete range to meet all architectural requirements.

CUBETTI



CUBETTO P 301



CUBETTO P 302



CUBETTO S 301



CUBETTO P 301/F



CUBETTO P 302/F



CUBETTO S 301/F

DESCRIZIONE: Lampada da parete, sorgente LED 230V, attacco E27.

Lampada da parete, sorgente LED 230V, attacco E27.

Lampada da soffitto, sorgente LED 230V, attacco E27.

DESCRIPTION: Wall lamp, LED 230V, E27.

Wall lamp, LED 230V, E27.

Ceiling lamp, LED 230V, E27.

DIMENSIONI:
DIMENSIONS:

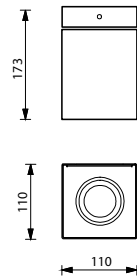
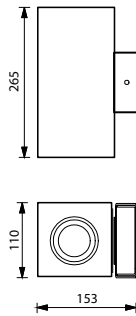
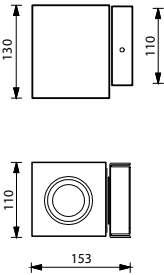

FINITURE: Ferro naturale cerato, bianco lucido.

Ferro naturale cerato, bianco lucido.

Ferro naturale cerato, bianco lucido.

FINISHES: Natural waxed iron, glossy whit.

Natural waxed iron, glossy white.

Natural waxed iron, glossy white.

LAMPADINE:  LED PAR 30 E27 D.R.

 2xLED PAR 30 E27 D.R.

 LED PAR 30 E27 D.R.

LAMPS:

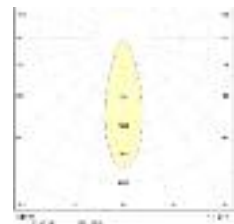
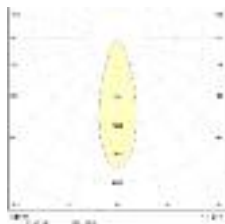
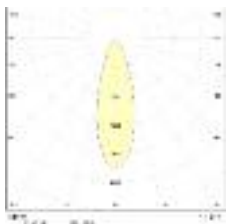



CUBETTO P301 DUO



CUBETTO S 301 DUO



CUBETTO P301 DUO/F



CUBETTO S301 DUO/F

DESCRIZIONE: Lampada da parete, sorgente LED 230V, attacco E27.

Lampada da soffitto, sorgente LED 230V, attacco E27.

DESCRIPTION: Wall lamp, LED 230V, E27.

Ceiling lamp, LED 230V, E27.

DIMENSIONI:
DIMENSIONS:

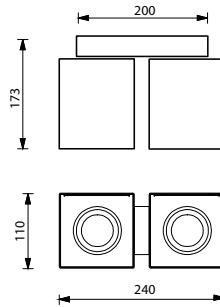
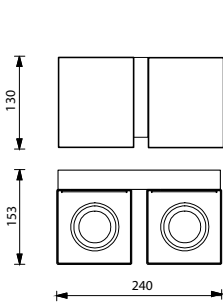

FINITURE: Ferro naturale cerato, bianco lucido.

Ferro naturale cerato, bianco lucido.

FINISHES Natural waxed iron, glossy whit.

Natural waxed iron, glossy white.

LAMPADINE:  2 x LED PAR 30 E27 D.R.

 2 x LED PAR 30 E27 D.R.

LAMPS:

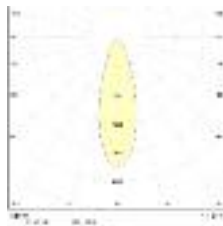
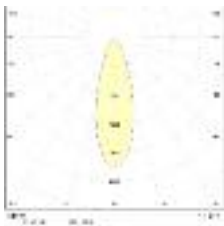

CUBETTI XS



CUBETTO P 161



CUBETTO P 162



CUBETTO S 161



CUBETTO P 161/F



CUBETTO P 162/F



CUBETTO S 161/F

DESCRIZIONE: Lampada da parete, sorgente LED 230V, attacco Gu10. Lampada da parete, sorgente LED 230V, attacco Gu10. Lampada da soffitto, sorgente LED 230V, attacco Gu10.

DESCRIPTION: Wall lamp, LED 230V, E27. Wall lamp, LED 230V, E27. Ceiling lamp, LED 230V, E27.

DIMENSIONI:
DIMENSIONS:

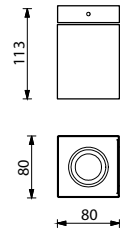
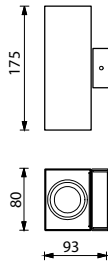
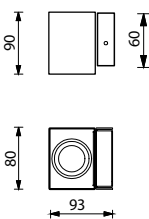

FINITURE: Ferro naturale cerato, bianco lucido. Ferro naturale cerato, bianco lucido. Ferro naturale cerato, bianco lucido.
FINISHES: Natural waxed iron, glossy whit. Natural waxed iron, glossy white. Natural waxed iron, glossy white.

LAMPADINE: LED GU10 D.R. 2xLED GU10 D.R. LED GU10 D.R.

LAMPS:

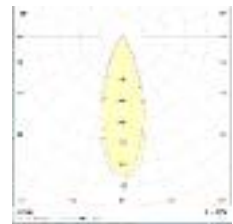
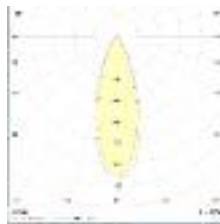
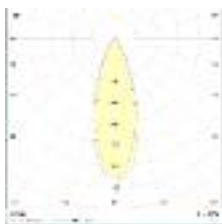



CUBETTO P161 DUO



CUBETTO P161 DUO/F

Lampada da parete, sorgente LED 230V, attacco Gu10.

Wall lamp, LED 230V, E27.

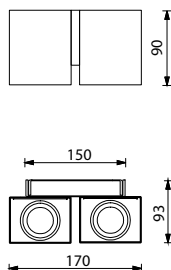

Ferro naturale cerato, bianco lucido.
Natural waxed iron, glossy whit.

2 x LED GU10 D.R.

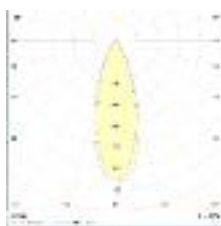

CUBETTO P162 DUO



CUBETTO P162 DUO/F

Lampada da parete, sorgente LED 230V, attacco Gu10.

Wall lamp, LED 230V, E27.

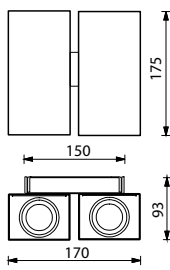

Ferro naturale cerato, bianco lucido.
Natural waxed iron, glossy white.

4 x LED GU10 D.R.

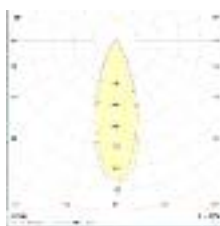

CUBETTO S 161 DUO



CUBETTO S 161 DUO/F

Lampada da soffitto, sorgente LED 230V, attacco Gu10.

Ceiling lamp, LED 230V, E27.

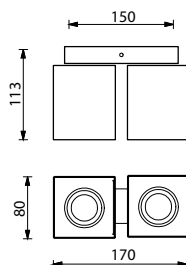

Ferro naturale cerato, bianco lucido.
Natural waxed iron, glossy white.

2 x LED GU10 D.R.

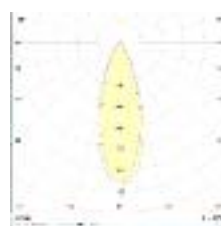

CUBETTI SNODO



CUBETTO S/P 301 SNODO



CUBETTO S/P 161 SNODO



CUBETTO S/P 161 DUO SNODO



CUBETTO S/P 301/F SNODO



CUBETTO S/P 161/F SNODO



CUBETTO S/P 161/F DUO SNODO

DESCRIZIONE: Lampada da parete o soffitto orientabile, sorgente LED 230V, attacco E27.

Lampada da parete o soffitto orientabile, sorgente LED 230V, attacco GU10.

Lampada da parete o soffitto orientabile, sorgente LED 230V, attacco GU10.

DESCRIPTION: Wall or ceiling adjustable lamp, 230V, E27.

Wall or ceiling adjustable lamp, 230V, GU10.

Wall or ceiling adjustable lamp, 230V, GU10.

DIMENSIONI:

DIMENSIONS:

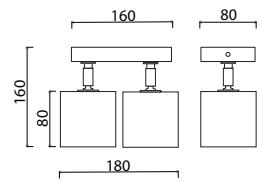
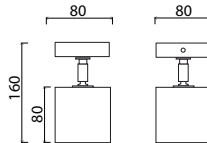
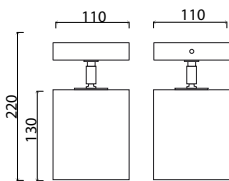

FINITURE: Ferro naturale cerato, bianco lucido.

Ferro naturale cerato, bianco lucido.

Ferro naturale cerato, bianco lucido.

FINISHES: Natural waxed iron, glossy whit.

Natural waxed iron, glossy white.

Natural waxed iron, glossy white.

LAMPADINE:

 LED PAR 30 E27 D.R.

 LED GU10 D.R.

 LED GU10 D.R.

LAMPS:

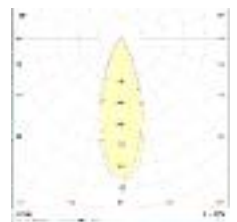
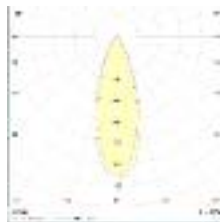
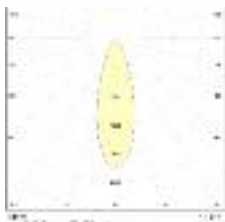









Quadra



Quadra, quando l'illuminazione diventa un'opera d'arte. Lampada da parete semplice e lineare, realizzata in ferro nero naturale cerato. L'utilizzo della lampadina Carbon filament le infonde un intenso sapore retrò.

Quadra, when the lighting becomes an Artwork. Wall lamp simple and linear, made in black iron waxed. The use of bulb in Carbon Filament give her a retro taste.

QUADRA



QUADRA

DESCRIZIONE: Realizzata in ferro nero naturale cerato a mano, equipaggiata con una lampada attacco E27.

DESCRIPTION: Realized in black natural iron waxed by hand, n. 1 bulbs E27.

DIMENSIONI:
DIMENSIONS:

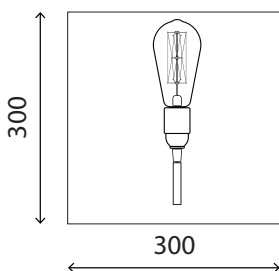

APPLICAZIONI: Adatto per l'illuminazione di ambienti commerciali e residenziali.

APPLICATIONS: Suitable for commercial and residential lighting.

FINITURE: Ferro naturale cerato.

FINISHES: Natural iron waxed.

LAMPADINA:
BULB:



Carbonfilament E27 40W - IP20 - D











giulia gatto

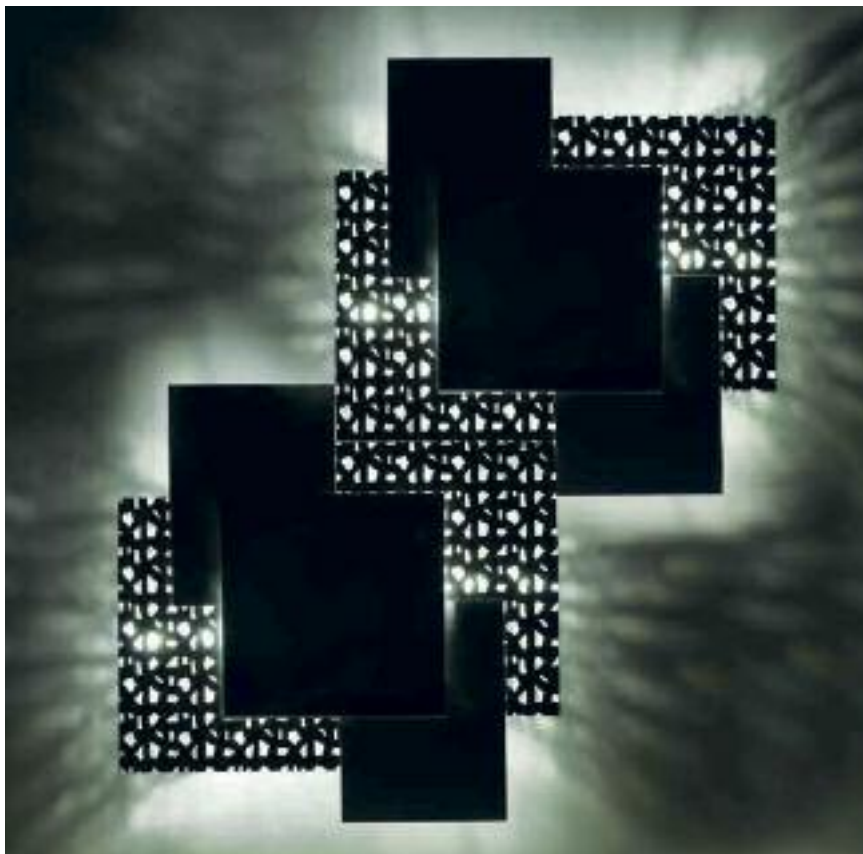

La lampada da parete KATÀ nasce dall'esperienza personale della Designer Giulia Gatto. Una luce morbida e avvolgente, riflessi irregolari e inaspettati, il progetto KATÀ rivisita la luce naturale filtrata dagli alberi per dare al nostro habitat armonia e serenità. Realizzata in ferro nero naturale cerato o laccata bianco lucido.

KATÀ wall lamp born from the personal experience of the designer Giulia Gatto. A soft light and enveloping, irregular and unexpected reflections, the project KATÀ revisits natural light filtered from the trees to give our habitat harmony and serenity. Made of black iron waxed or painted glossy white.

KATÀ



KATÀ

DESCRIZIONE: Lampada da parete in metallo, utilizza n. 4 lampadine LED E27 direttamente sostituibili.

DESCRIPTION: Iron wall lamp, using n. 4 LED bulbs E27 directly substitutable

DIMENSIONI:

DIMENSIOES:

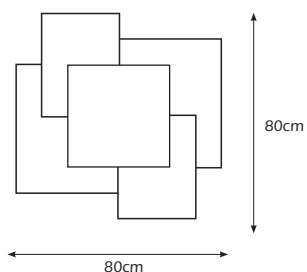

FINITURE: Bianco lucido, Sabbia intenso, grigio tortora, ferro naturale cerato.

FINISHES: White gloss, intense sand, dove grey, natural waxed iron.

APPLICAZIONI: Hotel e ambienti residenziali.

APPLICATIONS: Hotel and residential lighting.

LAMPADINA:



4 x LED 15W, IP 20 A+

BULB:

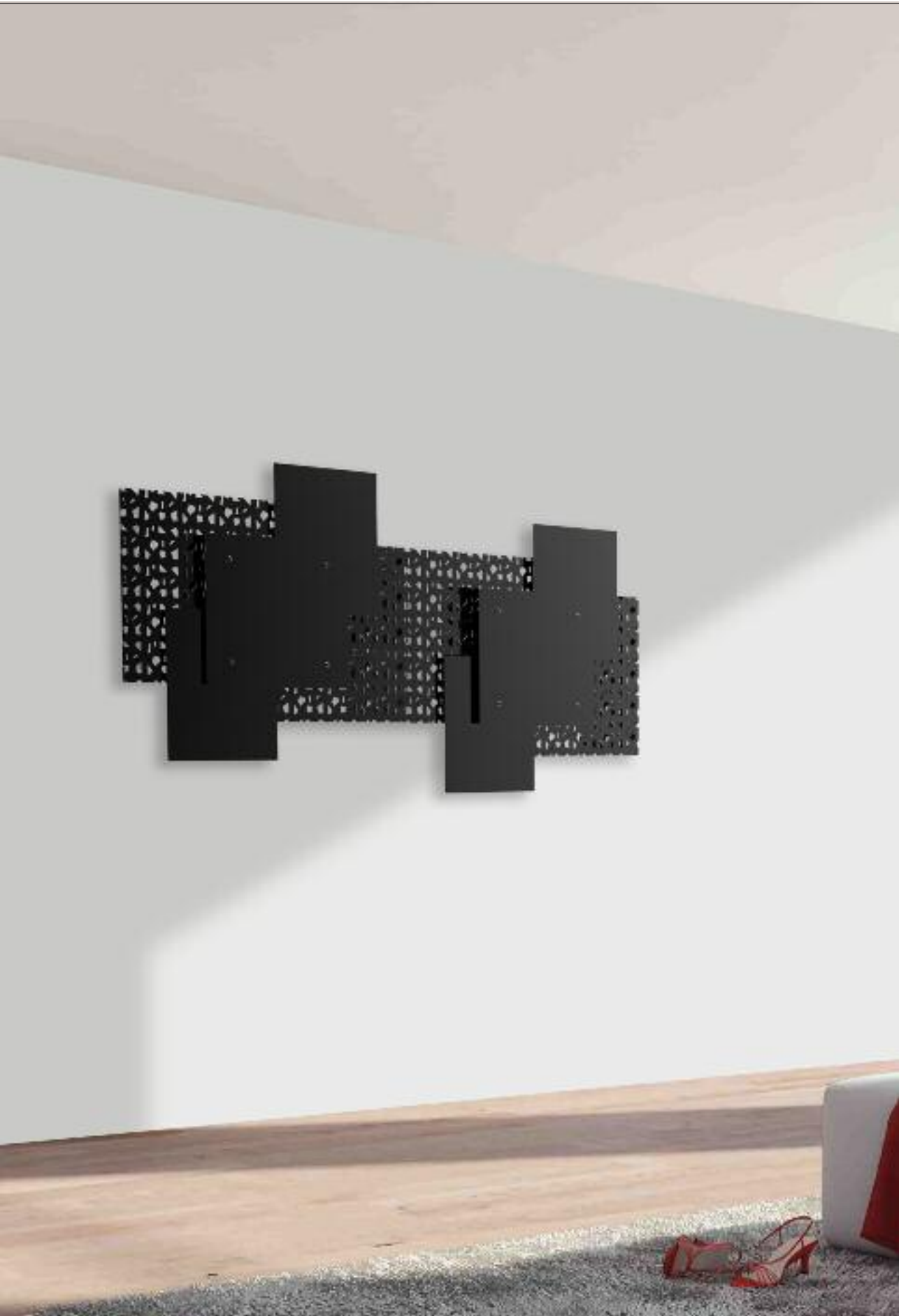





LAMPADE DA TAVOLO
TABLE LAMPS

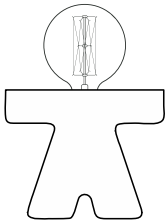

LOMINO

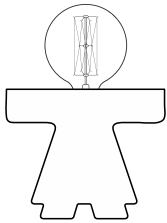

LUCIETTA

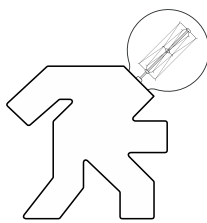

LOMINOCHECORRE

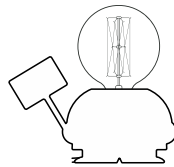

PINCO

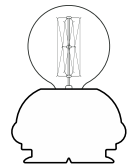

PALLO



imma lasalvia



Pochi ed essenziali elementi: una lampadina, una lamiera piegata e un filo. Il risultato è una lampada sorprendente.

Invece di nascondere la lampadina, la designer l'ha resa la parte principale del suo progetto: una testa geniale intorno a cui è stato disegnato un corpo. Anche se Lomino e la sua consorte Lucietta sembrano essere usciti da un fumetto, hanno già tutte le caratteristiche per diventare pezzi iconici del design italiano.

A few essential elements: a light bulb, a bent sheet metal and wire. The result is a surprising lamp.

Instead of trying to hide the bulb, the designer has made it the main feature of his project: a brilliant head around which a body was designed.

Although Lomino and his wife Lucietta seem to be out of a comic book, they have all the characteristics to become iconic pieces of Italian design.

LOMINO & LUCIETTA



LOMINO



LUCIETTA



LOMINO CHE CORRE

DESCRIZIONE: Lampada in metallo equipaggiata con una lampada attacco E27.

Lampada in metallo equipaggiata con una lampada attacco E27.

Lampada in metallo equipaggiata con una lampada attacco E27.

DESCRIPTION: Metal lamp, bulbs E27.

Metal lamp, bulbs E27

Metal lamp, bulbs E27

DIMENSIONI: 270x130xH320

270x130xH320

270x150xH280

DIMENSIONS:

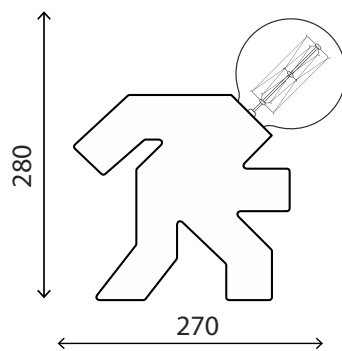
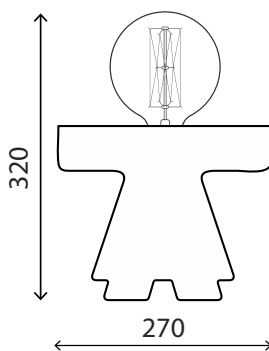
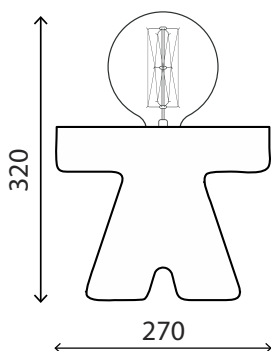

APPLICAZIONI: Adatto per l'illuminazione di ambienti residenziali.

Adatto per l'illuminazione di ambienti residenziali.

Adatto per l'illuminazione di ambienti residenziali.

APPLICATIONS: Suitable for residential lighting.

Suitable for residential lighting.

Suitable for residential lighting.

FINITURE: Ferro naturale cerato, bianco opaco, giallo senape, blu avio, viola rossastro.

Ferro naturale cerato, bianco opaco, giallo senape, blu avio, viola rossastro.

Ferro naturale cerato, bianco opaco, giallo senape, blu avio, viola rossastro.

FINISHES: Natural iron waxed, matte white, mustard yellow, blu avio, red violet.

Natural iron waxed, matte white, mustard yellow, blu avio, red violet.

Natural iron waxed, matte white, mustard yellow, blu avio, red violet.

LAMPADINA:
BULB:



Carbonfilament E27
40W - IP20 - D



Carbonfilament E27
40W - IP20 - D



Carbonfilament E27
40W - IP20 - D



Globo E27 - 14W
860lm - A



Globo E27 - 14W
860lm - A



Globo E27 - 14W
860lm - A



PINCO



PALLO

DESCRIZIONE: Lampada in metallo equipaggiata con una lampada attacco E27.

Lampada in metallo equipaggiata con una lampada attacco E27.

DESCRIPTION: Metal lamp, bulbs E27.

Metal lamp, bulbs E27

DIMENSIONI: 280x90xH240

190x90xH240

DIMENSION:

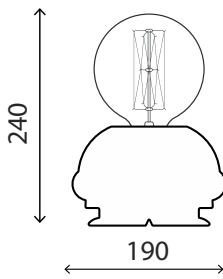
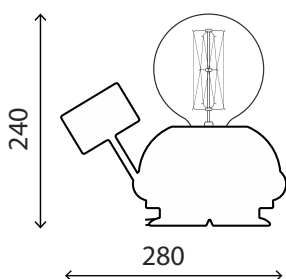

APPLICAZIONI: Adatto per l'illuminazione di ambienti residenziali.

Adatto per l'illuminazione di ambienti residenziali.

APPLICATIONS: Suitable for residential lighting.

Suitable for residential lighting.

FINITURE: Ferro naturale cerato, bianco opaco, giallo senape, blu avio, viola rossastro.

Ferro naturale cerato, bianco opaco, giallo senape, blu avio, viola rossastro.

FINITURE: Natural iron waxed, matte white, mustard yellow, blue avio, red violet.

Natural iron waxed, matte white, mustard yellow, blue avio, red violet.

LAMPADINA:
BULB:







TRAVI
TRACKS

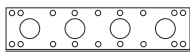

MEKKANO



TRUSS

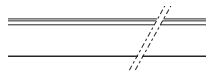

BINARIO

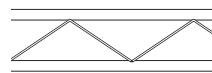

TRALICCI

TRAVE MK

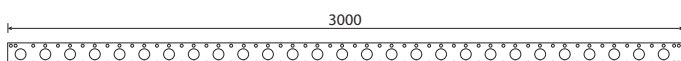
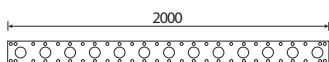
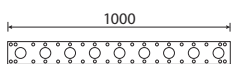
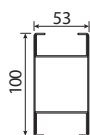

TRAVE MK
Moduli standard di Trave MK in alluminio, bianco o nero
Standard "Trave MK" girders in aluminum, white or black

PORTATA MAX 30 KG

TRAVE MK 100 0,009 2,2

TRAVE MK 200 0,015 3,9

TRAVE MK 300 0,023 5,4

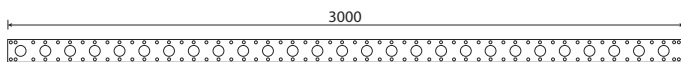
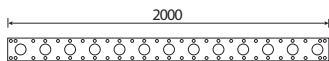
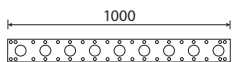
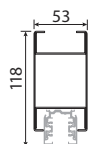

TRAVE MK "EB"
Moduli standard di Trave MK in alluminio, bianco o nero, completi di binario
elettrificato trifase con possibilità di 3 accensioni separate
Standard "Trave MK EB" girders in aluminum, white or black
with three-phase electrified binary for three separated ignitions (3F N FE)
Monocorpo elettrificato/ Electrified unit, IP 20 CLASSE I Trifase/Three-phase (3P+N+PE), Un 400V, In
16A 50Hz

TRAVE MK 100 EB 0,009 2,2

TRAVE MK 200 EB 0,015 3,9

TRAVE MK 300 EB 0,023 5,4

PST

Coppia giunto di continuità
Squadre joint

Finiture: acciaio zincato, bianco e nero
Finiture: galvanized iron, white and black



GT - 2B

Coppia giunto ad angolo
Right angle joint

Finiture: acciaio, bianco e nero
Finiture: galvanized iron, white and black

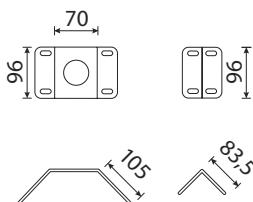

SM - 130

Coppia staffa fissaggio a parete

Wall connection

Finiture: acciaio, bianco e nero

Finiture: galvanized iron, white and black

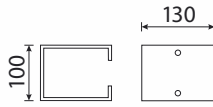

GNT

Coppia fissaggio a parete

"L" connection with holes

Finiture: acciaio, bianco e nero

Finiture: galvanized iron, white and black

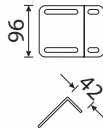

TRS

Tirante con fissaggio a soffitto

Adjustable tie-rods

Finiture: acciaio, bianco e nero

Finiture: galvanized iron, white and black

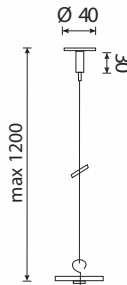

TA - 41

Chiusura terminale trave

Terminal plug

Finiture: alluminio naturale, bianco e nero

Finiture: galvanized iron, white and black

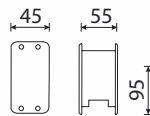

TLL1

Coppia tirante a L lungo

"L" long connection

Finiture: acciaio, bianco e nero

Finiture: galvanized iron, white and black

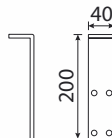

TLL2

Coppia tirante a L lungo

"L" long connection

Finiture: acciaio, bianco e nero

Finiture: galvanized iron, white and black

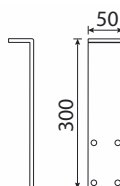

ESEMPIO/EXAMPLE

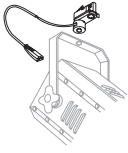

XTSA-F
 Finitura: bianco e nero
 Finiture: white and black

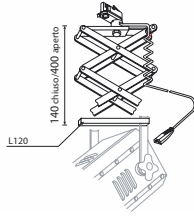

XTSAF-PP
 Finitura: alluminio zincato
 Finiture: galvanized aluminum

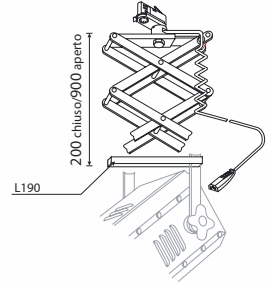

XTSAF-PG
 Finitura: alluminio zincato, nero e bianco
 Finiture: galvanized aluminum, black and white

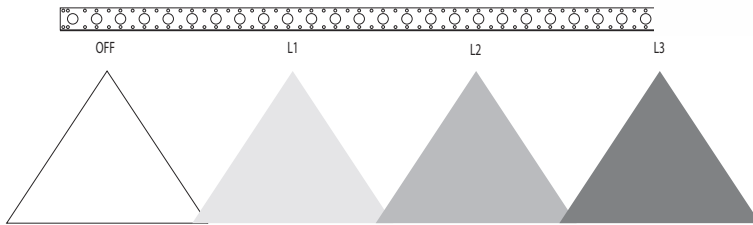

Sistema TRAVE MK "EB" costituito da elementi standard completi di binario elettrificato trifase con possibilità di 3 accensioni separate
 Electrified "EB" TRAVE MK system with electric plugs at separated circuits

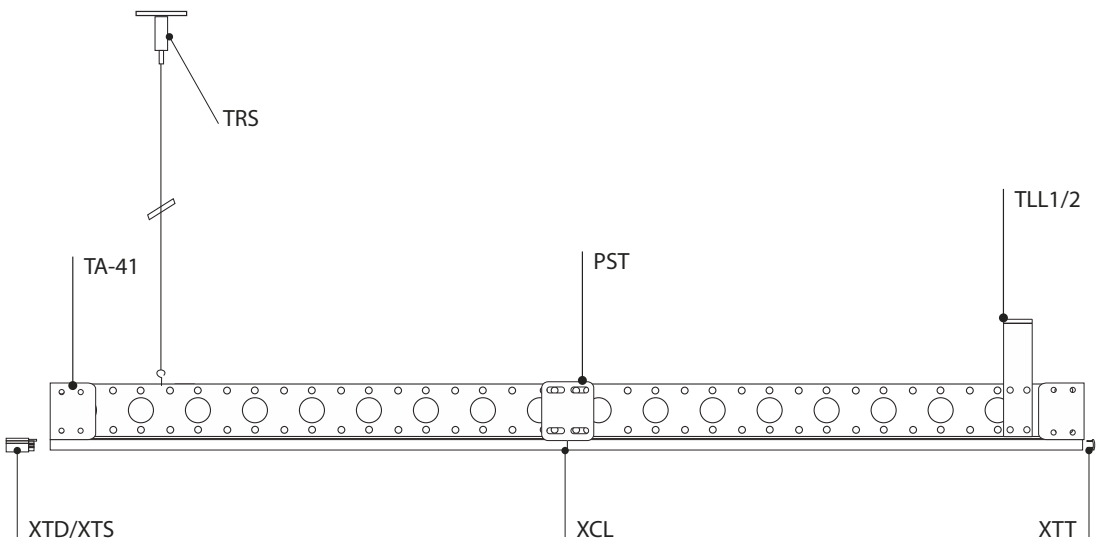



TRAVE TR

TRAVE TR

Moduli standard di Trave TR in alluminio, bianco e nero
Standard "Trave TR" girders in aluminum, white and black

Portata max 30 kg

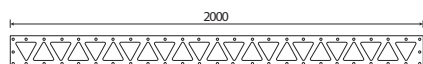
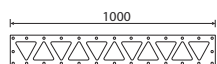
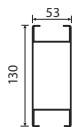

TRAVE TR 100



TRAVE TR 200



TRAVE TR 300



TRAVE TR "EB"

Moduli standard di Trave TR in alluminio, bianco e nero completi di binario elettrificato trifase con possibilità di 3 accensioni separate
Standard "TRAVE TR" girders in aluminum, white and black, with three-phase electrified binary for three separated ignitions (3F N FE)

Monocorpo elettrificato/ Electrified unit, IP 20 CLASSE I Trifase/Three-phase (3P+N+PE), Un 400V, In 16A 50Hz

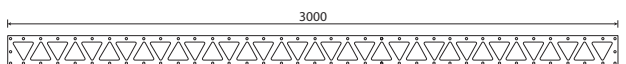
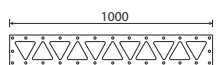
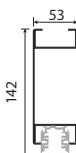

TRAVE TR 100 EB



TRAVE TR 200 EB



TRAVE TR 300 EB



ST 130

Coppia staffa fissaggio a parete

Wall connection

Finiture: acciaio zincato, bianco e nero

Finiture: galvanized iron, white and black

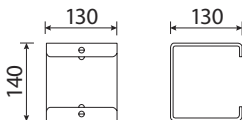

TCT

Coppia staffa fissaggio a parete

Wall connection

Finiture: acciaio zincato, bianco e nero

Finiture: galvanized iron, white and black

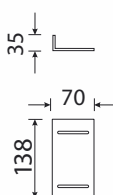

TCT-EB

Chiusura terminale

Terminal plug

Finiture: acciaio zincato, bianco e nero

Finiture: galvanized iron, white and black

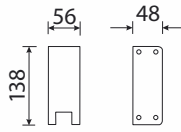

SAT

Coppia giunto ad angolo

Right angle joint

Finiture: acciaio zincato, bianco e nero

Finiture: galvanized iron, white and black

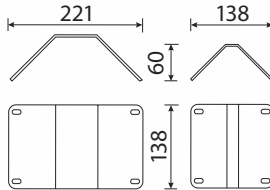

TRS

Tirante con fissaggio a soffitto

Adjustable tie-rods

Finiture: acciaio zincato, bianco e nero

Finiture: galvanized iron, white and black

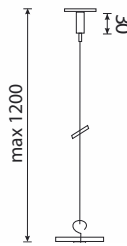

SLT1

Coppia tirante a L lungo

"L" long connection

Finiture: acciaio zincato, bianco e nero

Finiture: galvanized iron, white and black

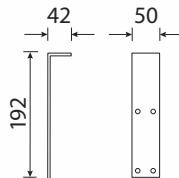

SLT2

Coppia tirante a L lungo

"L" long connection

Finiture: acciaio zincato, bianco e nero

Finiture: galvanized iron, white and black

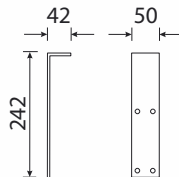

PST2

Coppia giunto di continuità

Squadre joint

Finiture: acciaio zincato, bianco e nero

Finiture: galvanized iron, white and black

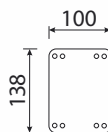

ESEMPIO/EXAMPLE

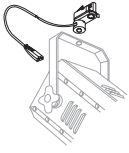

XTSA-F

Finitura: bianco e nero
Finiture: white and black

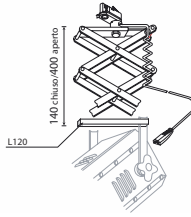

XTSAF-PP

Finitura: alluminio zincato
Finiture: galvanized aluminum

XTSAF-PG

Finitura: alluminio zincato, nero e bianco
Finiture: galvanized aluminum, black and white

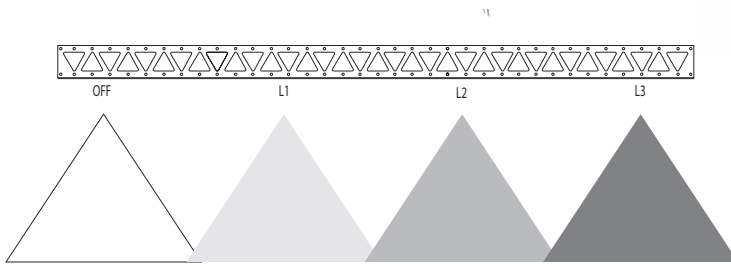
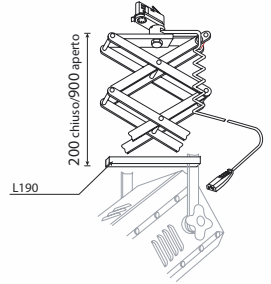

Sistema TRAVE TR "EB" costituito da elementi standard completi di binario elettrificato trifase con possibilità di 3 accensioni separate
Electrified "EB" TRAVE TR system with electric plugs at separated circuits

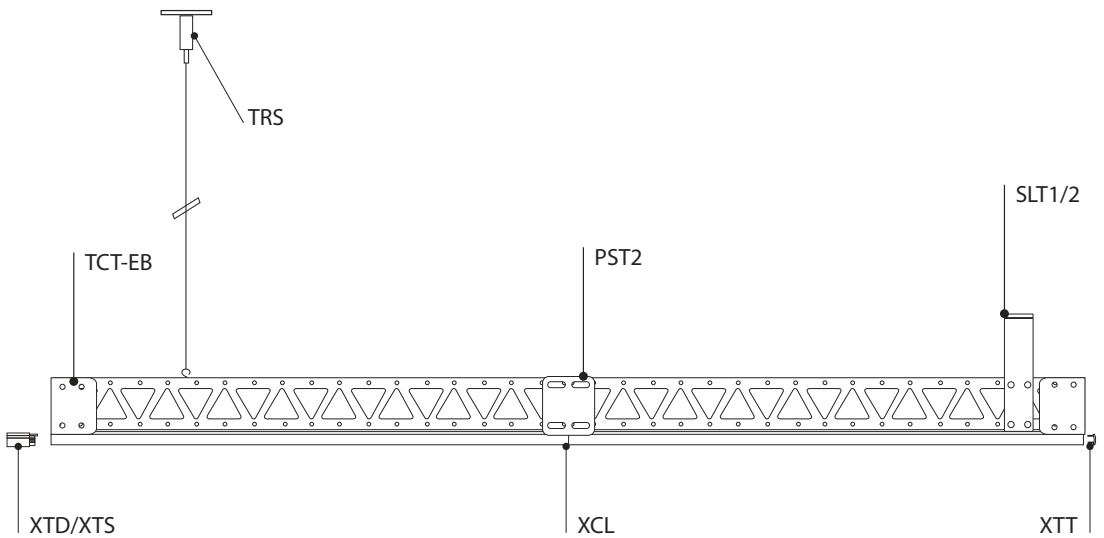







BINARIO ELETRIFICATO TRIFASE E ACCESSORI
THREE-PHASE TRACK AND ACCESSORIES

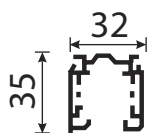

BINARIO ELETRIFICATO TRIFASE

Three-phase track
Finiture: alluminio, bianco e nero
Finiture: aluminum, white and black

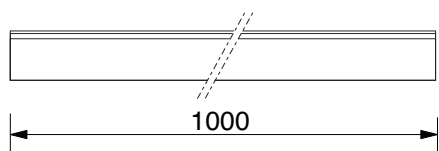

BIN - 100

m^3 0,0011 kg 0,8

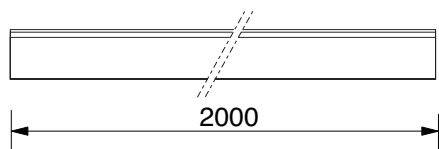

BIN - 200

m^3 0,0022 kg 1,6

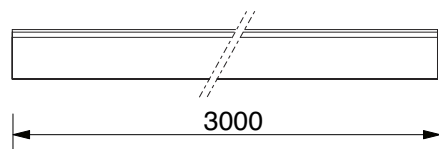

BIN - 300

m^3 0,0033 kg 2,4

XFA

Giunto flessibile
Flexible joint
Finiture: bianco, nero
Finiture: white, black

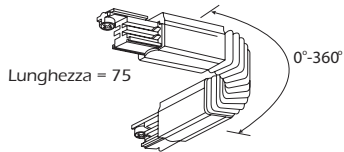

XTD/XTS

Supply
Finiture: bianco, nero
Finiture: white, black

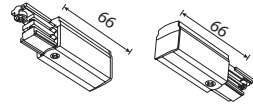

XCL

Giunto a scomparsa
Blind Joint
Finiture: bianco, nero
Finiture: white, black



XTT

Testata di chiusura
End cap
Finiture: bianco, nero
Finiture: white, black



XTSA-F

Kit attacco a binario
Kit attack on track
Finiture: bianco, nero
Finiture: white, black

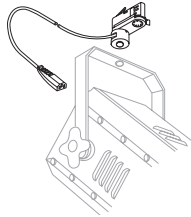

XTSA-PG/XTSA-PP

Adattatore a binario con pantografo
Track adapter with pantograph
Finitura: alluminio zincato, nero e bianco
Finiture: galvanized aluminum, black and white

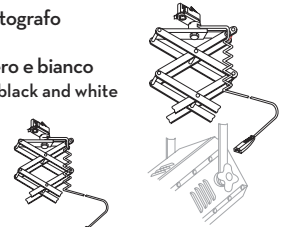







MODULI STANDARD DI TRALICCI DASA IN ALLUMINIO NATURALE

Moduli standard di tralicci in alluminio naturale per la realizzazione di strutture di sostegno ai proiettori DASA. Disponibili nella forma triangolare e nella forma quadrata ed in quattro misure diverse.

STANDARD MODULES OF DASA NATURAL ALUMINUM TRELLIS

Standard modules of natural aluminum trellises for the realization of support structures for DASA projectors. Available in the triangular shape and the square shape and in four different sizes.

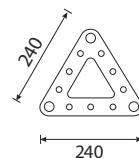

TRALICCIO TRIO

TRIO50

TRIO100

TRIO200

TRIO300

500

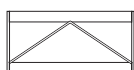

1000

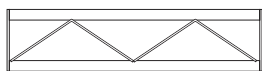

2000

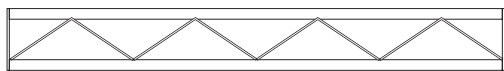

3000

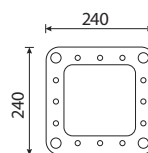
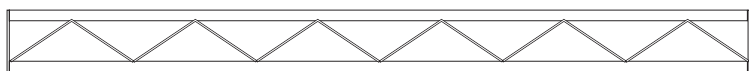

TRALICCIO QUADRO

QUADRO50

QUADRO100

QUADRO200

QUADRO300

500

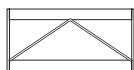

1000

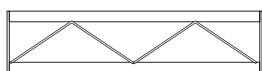

2000

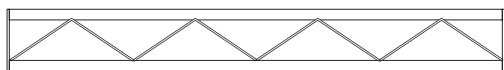

3000

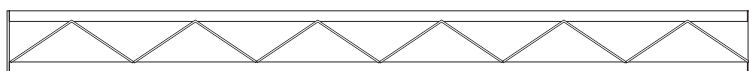

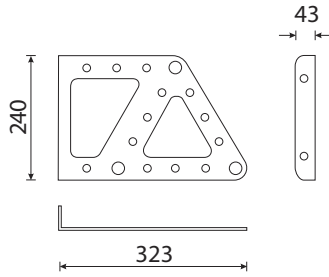

TAL-24
Staffa fissaggio parete in alluminio
Wall aluminium bracket

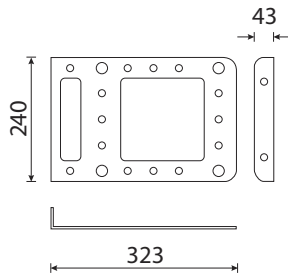

TAL-25
Staffa fissaggio parete in alluminio
Wall aluminium bracket

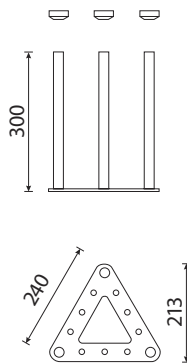

PTL-3
Piastra telescopica in alluminio
Telescopic aluminium connection

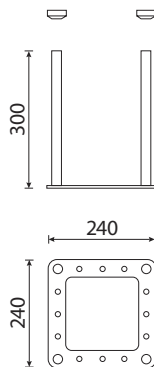

PTL-4
Piastra telescopica in alluminio
Telescopic aluminium connection

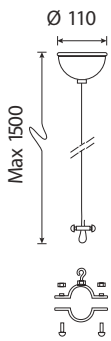

AU - 110

Tirante con rosone e collare
Connection to ceiling

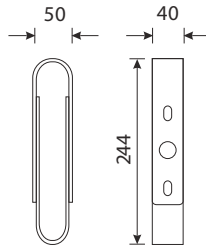

GLQ - 240

Staffa fissaggio trave in alluminio
Beam aluminium bracket

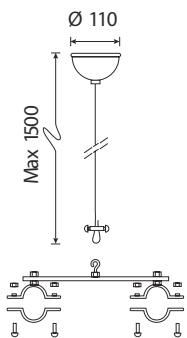

AU - 60G

Tirante con rosone e collare
Connection to ceiling

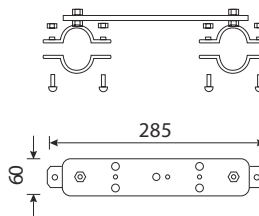

AU - 60

Staffa fissaggio faro in acciaio zincato
Steel galvanized bracket for spot

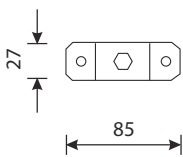
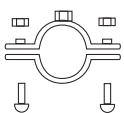

AU - 27
Staffa fissaggio faro
Bracket for spot

KIT-TRIO
Kit montaggio trave TRIO
Kit assembly for TRIO beam

KIT-QUADRO
Kit montaggio trave QUADRO
Kit assembly for QUADRO beam





GN-TR90

DIM. 480X480MM

Elemento di giunzione 90° per traliccio TRIO in alluminio
Junction aluminium element 90° for TRIO truss



GN-TR180

DIM. 720X480MM

Elemento di giunzione 90/180° per traliccio TRIO in alluminio
Junction aluminium element 90/180° for TRIO truss



GQ-360

DIM. 240X240MM

Elemento di giunzione 90/180/360° per traliccio QUADRO in alluminio
Junction aluminium element 90/180/360° for QUADRO truss





**“Un grazie a chi ci ha insegnato che lavorare
con gioia, passione e dedizione
è il segreto per arrivare al successo.”**



OFFICINE DASA #3 anno 2016

Graphic project: Imma Lasalvia

È vietata la riproduzione anche parziale del contenuto dei testi e delle immagini. L'azienda si riserva il diritto di apportare ai propri prodotti qualsiasi modifica ritenuta utile al miglioramento qualitativo degli stessi, sia dimensionale che strutturale. Foto, disegni e test non hanno carattere contrattuale.

Per eventuali aggiornamenti fare riferimento al sito web www.officinedasa.it

The reproduction of texts and images, even in partial, is forbidden.

The company reserves the right to modify the dimensions and structure of its products at any time without prior notice in order to improve quality and durability. Photo, drawings and texts are not contractual. Please refer to web site www.officinedasa.it for any update.

DASA

LIGHT YOUR LIFE

OFFICINE DASA Srl
Via della Cereria, 11
00071 Pomezia (Roma) - Italy
Tel. (+39) 06.91621001 r.a.
Fax (+39) 06.91626677

officinedasa@officinedasa.it
www.officinedasa.it